

# Technical data sheet

## Product features



### Electric fryer 18+18 l electronic 7” TouchSreen, filtration

<b>Model</b>	<b>SAP Code</b>	00014423
--------------	-----------------	----------



- Basin volume [l]: 18
- Drain type: Trough the cabinet
- Drain: Yes
- Maximum device temperature [°C]: 190
- Minimum device temperature [°C]: 50
- Material: AISI 304
- Number of baskets: 4
- Basket dimensions [mm x mm x mm]: 135x290x150

<b>SAP Code</b>	00014423	<b>Loading</b>	400 V / 3N - 50 Hz
<b>Net Width [mm]</b>	800	<b>Basin volume [l]</b>	18
<b>Net Depth [mm]</b>	900	<b>Number of basins</b>	2
<b>Net Height [mm]</b>	900	<b>Number of baskets</b>	4
<b>Net Weight [kg]</b>	138.00	<b>Basket dimensions [mm x mm x mm]</b>	135x290x150
<b>Power electric [kW]</b>	32.400	<b>Production of fries [kg/h]</b>	54

# Technical data sheet

Technical drawing



Electric fryer 18+18 l electronic 7" TouchSreen, filtration

Model

SAP Code

00014423

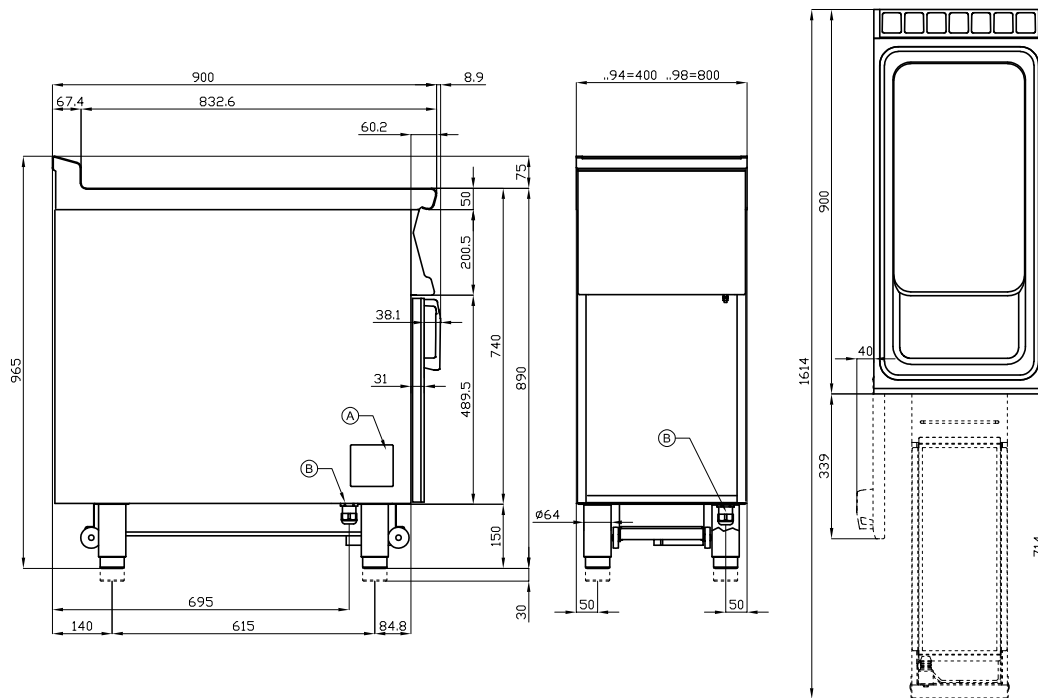

A	Data plate	B	Electrical connection
---	------------	---	-----------------------

# Technical data sheet

Technical parameters



## Electric fryer 18+18 l electronic 7" TouchSreen, filtration

**Model**

**SAP Code**

00014423

**1. SAP Code:**

00014423

**2. Article group:**

Fryers

**3. Net Width [mm]:**

800

**4. Net Depth [mm]:**

900

**5. Net Height [mm]:**

900

**6. Net Weight [kg]:**

138.00

**7. Gross Width [mm]:**

100

**8. Gross depth [mm]:**

970

**9. Gross Height [mm]:**

1110

**10. Gross Weight [kg]:**

143.00

**11. Device type:**

Electric unit

**12. Construction type of device:**

Under table

**13. Power electric [kW]:**

32.400

**14. Loading:**

400 V / 3N - 50 Hz

**15. Protection of controls:**

IPX5

**16. Device color:**

Stainless steel

**17. Material:**

AISI 304

**18. Indicators:**

operation and warm-up

**19. Worktop type:**

Molded - comfortable cleaning maintenance

**20. Basin volume [l]:**

18

**21. Basin dimensions [mm x mm x mm]:**

310x340x330

**22. Maximum device temperature [°C]:**

190

**23. Minimum device temperature [°C]:**

50

**24. Safety thermostat:**

Yes

**25. Adjustable feet:**

Yes

**26. Heating element material:**

AISI 304

**27. Number of baskets:**

4

**28. Number of basins:**

2

# Technical data sheet

Technical parameters



## Electric fryer 18+18 l electronic 7" TouchSreen, filtration

**Model**

**SAP Code**

00014423

### 29. Basket dimensions [mm x mm x mm]:

135x290x150

### 32. Drain type:

Trough the cabinet

### 30. Basin material:

AISI 304 - High quality stainless steel

### 33. Drain:

Yes

### 31. Production of fries [kg/h]:

54