

# Technical data sheet

## Product features



### Cooking range electric with static electric oven GN 2/1 - 6x plate 400 V

<b>Model</b>	<b>SAP Code</b>	00000336
--------------	-----------------	----------



- Device type: Electric unit
- Power consumption of the zone 1 [kW]: 2,6
- Power consumption of the zone 2 [kW]: 2,6
- Power consumption of the zone 3 [kW]: 2,6
- Power consumption of the zone 4 [kW]: 2,6
- Power consumption of the zone 5 [kW]: 2,6
- Power consumption of the zone 6 [kW]: 2,6
- Type of internal part of the appliance 1 (eg oven): Electric
- Type of internal part of the appliance 2 (eg oven): Static
- Protection of controls: IPX5
- Material: Stainless steel

<b>SAP Code</b>	00000336	<b>Power consumption of the zone 3 [kW]</b>	2,6
<b>Net Width [mm]</b>	1200	<b>Power consumption of the zone 4 [kW]</b>	2,6
<b>Net Depth [mm]</b>	705	<b>Power consumption of the zone 5 [kW]</b>	2,6
<b>Net Height [mm]</b>	900	<b>Power consumption of the zone 6 [kW]</b>	2,6
<b>Net Weight [kg]</b>	129.00	<b>Type of internal part of the appliance 1 (eg oven)</b>	Electric
<b>Power electric [kW]</b>	20.600	<b>Type of internal part of the appliance 2 (eg oven)</b>	Static
<b>Loading</b>	400 V / 3N - 50 Hz	<b>Width of internal part [mm]</b>	670
<b>Number of zones</b>	6	<b>Depth of internal part [mm]</b>	550
<b>Power consumption of the zone 1 [kW]</b>	2,6	<b>Height of internal part [mm]</b>	340
<b>Power consumption of the zone 2 [kW]</b>	2,6		

# Technical data sheet

Technical drawing



Cooking range electric with static electric oven GN 2/1 - 6x plate 400 V

Model

SAP Code

00000336

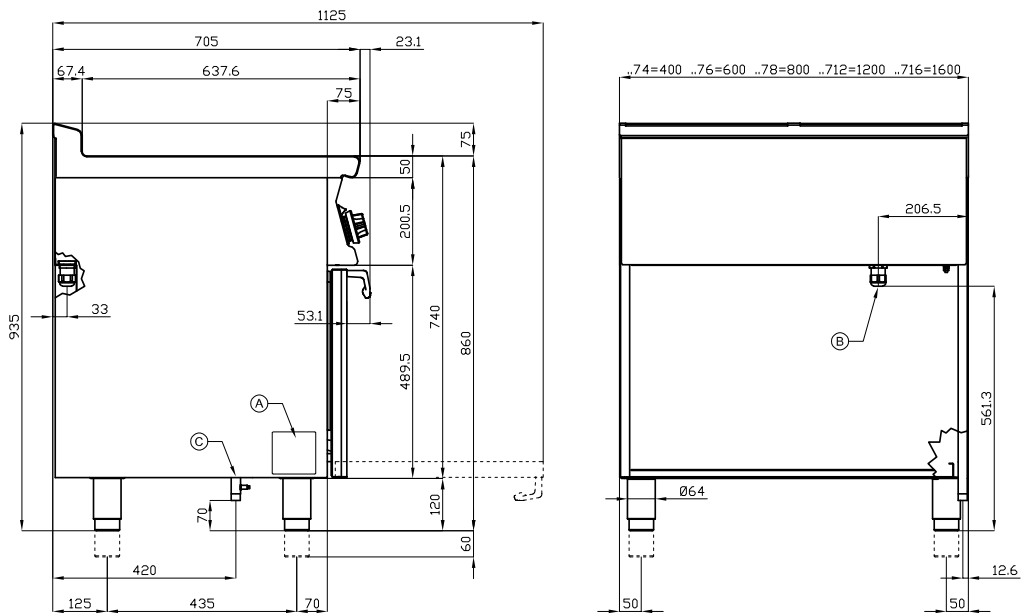

A	Data plate	B	Electrical connection
---	------------	---	-----------------------

# Technical data sheet

## Product benefits



### Cooking range electric with static electric oven GN 2/1 - 6x plate 400 V

Model

SAP Code

00000336

1

#### Internal thermostatic plate protection

longer service life of the plates  
– no overheating of the plates and no cracking

2

#### Degree of protection of the control elements IPX5

maintenance-free system  
resistance to splash water  
long life  
– savings on service interventions  
– easy cleaning and maintenance of equipment

3

#### All-stainless design

the material does not cut  
wear resistance of the material  
long life  
– savings on service interventions  
– easy cleaning and maintenance of equipment

4

#### Hygienic moldings of the top plate

absence of sharp corners and edges (potential places where dirt could stick)  
smooth transitions  
– easy quick cleaning

5

#### Large oven with four rack positions with static cooking

static baking  
high capacity and variability  
all-stainless design  
– suitable for yeast dishes and desserts  
– long service life  
– easy to clean

# Technical data sheet

Technical parameters



## Cooking range electric with static electric oven GN 2/1 - 6x plate 400 V

**Model**

**SAP Code**

00000336

**1. SAP Code:**

00000336

**2. Net Width [mm]:**

1200

**3. Net Depth [mm]:**

705

**4. Net Height [mm]:**

900

**5. Net Weight [kg]:**

129.00

**6. Gross Width [mm]:**

1230

**7. Gross depth [mm]:**

770

**8. Gross Height [mm]:**

1110

**9. Gross Weight [kg]:**

146.00

**10. Device type:**

Electric unit

**11. Construction type of device:**

With substructure

**12. Power electric [kW]:**

20.600

**13. Loading:**

400 V / 3N - 50 Hz

**14. Protection of controls:**

IPX5

**15. Material:**

Stainless steel

**16. Worktop type:**

Molded - comfortable cleaning maintenance

**17. Worktop material:**

AISI 304

**18. Worktop Thickness [mm]:**

2.00

**19. Number of zones:**

6

**20. Power consumption of the zone 1 [kW]:**

2,6

**21. Power consumption of the zone 2 [kW]:**

2,6

**22. Power consumption of the zone 3 [kW]:**

2,6

**23. Power consumption of the zone 4 [kW]:**

2,6

**24. Power consumption of the zone 5 [kW]:**

2,6

**25. Power consumption of the zone 6 [kW]:**

2,6

**26. Maximum device temperature [°C]:**

300

**27. Minimum device temperature [°C]:**

50

**28. Number of power control stages:**

6

# Technical data sheet

Technical parameters



## Cooking range electric with static electric oven GN 2/1 - 6x plate 400 V

**Model**

**SAP Code**

00000336

### 29. Service accessibility:

From the front by removing the front panel and waste fluid containers

### 30. Safety element:

internal thermostatic protection of the hotplate against overheating  
safety thermostat 360 Â°C

### 31. Safety thermostat:

Yes

### 32. Safety thermostat up to x Â° C:

360

### 33. Adjustable feet:

Yes

### 34. Additional information:

cabinet with door

### 35. Number of burners/hot plates:

6

### 36. Type of electric cooking zones:

Squared

### 37. Oven Type:

electrical static

### 38. Oven size:

GN 2/1

### 39. Oven material:

Stainless steel

### 40. Type of internal part of the appliance 1 (eg oven):

Electric

### 41. Type of internal part of the appliance 2 (eg oven):

Static

### 42. Width of internal part [mm]:

670

### 43. Depth of internal part [mm]:

550

### 44. Height of internal part [mm]:

340

### 45. Maximum temperature of the inner chamber [Â°C]:

300

### 46. Minimum temperature of the inner chamber [Â°C]:

50

### 47. Number of internal parts:

4