

# Technical data sheet



## Product features

<b>Model</b>	<b>SAP Code</b>	00012413
FTHC 70/80 E	<b>A group of articles - web</b>	Grills and grill plates



- Top type: Smooth
- Griddle dimensions [mm x mm]: 800 x 510
- Griddle thickness [mm]: 12.00
- Worktop material: Chrome plated steel
- Container for liquid fat: Yes
- Independent heating zones: Separate control for each heating zone
- Maximum device temperature [°C]: 300
- Surface finish: polished chrome 0.03 mm
- Removable rim: Yes

<b>SAP Code</b>	00012413	<b>Power electric [kW]</b>	9.000
<b>Net Width [mm]</b>	800	<b>Loading</b>	400 V / 3N - 50 Hz
<b>Net Depth [mm]</b>	700	<b>Griddle dimensions [mm x mm]</b>	800 x 510
<b>Net Height [mm]</b>	900	<b>Top type</b>	Smooth
<b>Net Weight [kg]</b>	81.00		

# Technical data sheet



Technical drawing

<b>Model</b>	<b>SAP Code</b>	00012413
FTHC 70/80 E	<b>A group of articles - web</b>	Grills and grill plates

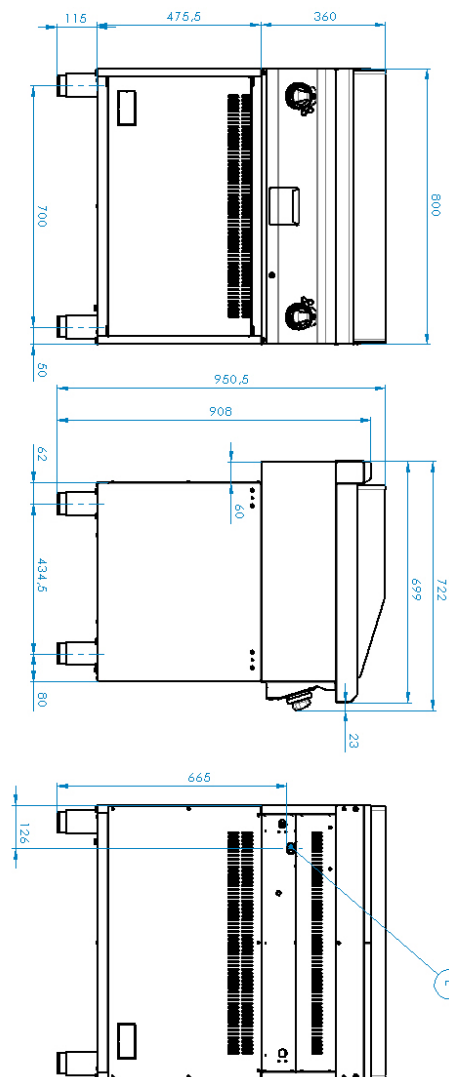

# Technical data sheet



## Product benefits

<b>Model</b>	<b>SAP Code</b>	00012413
FTHC 70/80 E	<b>A group of articles - web</b>	Grills and grill plates

- 1 All-stainless design**
  - long life
  - corrosion resistance of the top plate material
    - savings on service interventions
    - easier and faster operation
- 2 Degree of protection of the control elements IPX4**
  - maintenance-free system
  - resistance to splash water
  - long life
    - savings on service interventions
    - easy cleaning and maintenance of equipment
- 3 Outlet for waste liquids**
  - ensures that oil drips into the socket
    - easy maintenance
    - easy cleaning
- 4 High detachable hem**
  - better hygienic conditions
  - preventing grease from splashing onto ancillary equipment
    - easy maintenance
    - easy cleaning
- 5 Smooth plate made of chrome-plated steel**
  - the product bakes less and is easier to clean
  - a good warming of the meat with a groove
    - time-saving for food preparation
    - no reheating and long cooking times

# Technical data sheet



## Technical parameters

<b>Model</b>	<b>SAP Code</b>	00012413
FTHC 70/80 E	<b>A group of articles - web</b>	Grills and grill plates

**1. SAP Code:**

00012413

**2. Article group:**

RF-Line 700

**3. Net Width [mm]:**

800

**4. Net Depth [mm]:**

700

**5. Net Height [mm]:**

900

**6. Net Weight [kg]:**

81.00

**7. Gross Width [mm]:**

840

**8. Gross depth [mm]:**

800

**9. Gross Height [mm]:**

975

**10. Gross Weight [kg]:**

95.00

**11. Device type:**

Electric unit

**12. Construction type of device:**

Stationary

**13. Power electric [kW]:**

9.000

**14. Loading:**

400 V / 3N - 50 Hz

**15. Protection of controls:**

IPX4

**16. Material:**

AISI 304 top plate, AISI 430 cladding

**17. Indicators:**

operation and warm-up

**18. Worktop material:**

Chrome plated steel

**19. Worktop Thickness [mm]:**

1.20

**20. Surface finish:**

polished chrome 0.03 mm

**21. Maximum device temperature [°C]:**

300

**22. Minimum device temperature [°C]:**

50

**23. Service accessibility:**

Trough the frontal panel

**24. Safety thermostat:**

Yes

**25. Adjustable feet:**

Yes

**26. Griddle dimensions [mm x mm]:**

800 x 510

**27. Griddle thickness [mm]:**

12.00

**28. Container for liquid fat:**

Yes

**29. Independent heating zones:**

Separate control for each heating zone

**30. Removable rim:**

Yes

**31. Top type:**

Smooth