

Technical data sheet

Product features



Cooking range solid top gas 1x burner without cabinet

Model	SAP Code	00005858
--------------	-----------------	----------



- Device type: Gas unit
- Power consumption of the zone 1 [kW]: 7
- Ignition: Piezo+veřnř plamen
- Protection of controls: IPX5
- Material: Stainless steel

SAP Code	00005858	Power gas [kW]	7.000
Net Width [mm]	400	Type of gas	Natural gas, propane butane
Net Depth [mm]	705	Number of zones	1
Net Height [mm]	280	Power consumption of the zone 1 [kW]	7
Net Weight [kg]	55.00	Solid top dimensions [mm x mm]	370 x 570

Technical data sheet

Technical drawing



Cooking range solid top gas 1x burner without cabinet

Model	SAP Code	00005858
--------------	-----------------	----------

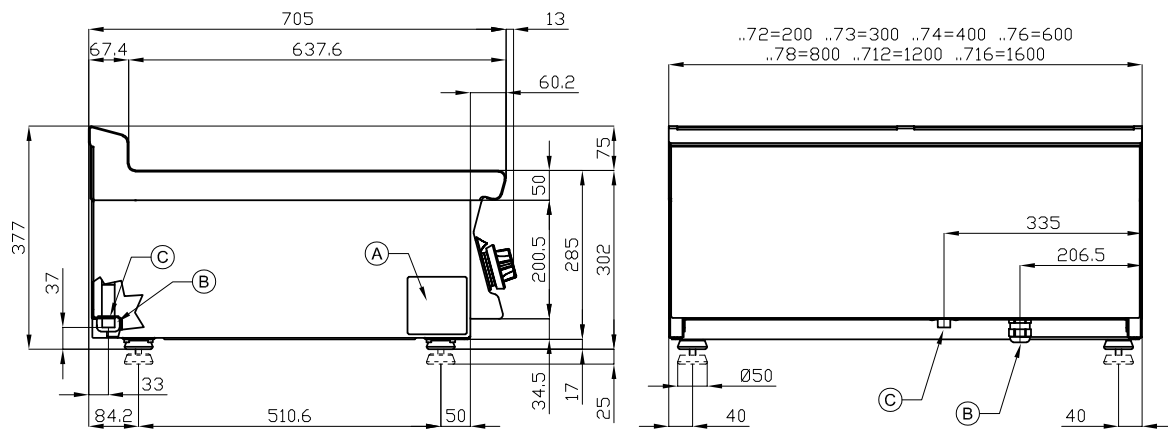

A	Data plate		C	Gas connection	ISO 7-1 1/2" M
---	------------	--	---	----------------	----------------

Technical data sheet

Product benefits



Cooking range solid top gas 1x burner without cabinet

Model

SAP Code

00005858

1

Massive construction of burners

high performance and efficiency
cast iron burners removable
long life

- energy saving (perfect combustion)
- time saving for food preparation
- easy maintenance/cleaning

2

Hygienic moldings of the top plate

absence of sharp corners and edges (potential places where dirt could stick)
smooth transitions

- easy quick cleaning

3

Degree of protection of the control elements IPX5

maintenance-free system
resistance to splash water
long life

- savings on service interventions
- easy cleaning and maintenance of equipment

4

All-stainless design

the material does not cut
wear resistance of the material
long life

- savings on service interventions
- easy cleaning and maintenance of equipment

5

Safety element "thermocouple"

safe operation for personnel
there is no overheating and damage to the thallus
long life

- savings on service interventions
- easier and faster operation

6

Piezoelectric ignition

instant flame ignition
there is no unnecessary gas leakage
long life

- savings on service interventions
- easier and faster operation

7

Massive thal

15mm material ensures even distribution of heat and heating of the product (heat several pots at the same time at the same temperature)
material resistance
long life

- time saving
- ease of operation
- savings on service interventions

8

Cooking unit for use on a table or on a base

variable use
the possibility of placement in smaller spaces

- easy handling
- cost savings on substructure

Technical data sheet

Technical parameters



Cooking range solid top gas 1x burner without cabinet

Model

SAP Code

00005858

1. SAP Code:

00005858

2. Net Width [mm]:

400

3. Net Depth [mm]:

705

4. Net Height [mm]:

280

5. Net Weight [kg]:

55.00

6. Gross Width [mm]:

430

7. Gross depth [mm]:

770

8. Gross Height [mm]:

540

9. Gross Weight [kg]:

60.00

10. Device type:

Gas unit

11. Construction type of device:

Table top

12. Power gas [kW]:

7.000

13. Ignition:

Piezo+veÄŤnÄŤ plamen

14. Type of gas:

Natural gas, propane butane

15. Protection of controls:

IPX5

16. Material:

Stainless steel

17. Worktop type:

Molded - comfortable cleaning maintenance

18. Worktop material:

AISI 304

19. Worktop Thickness [mm]:

2.00

20. Number of zones:

1

21. Power consumption of the zone 1 [kW]:

7

22. Number of power control stages:

6

23. Service accessibility:

From the front by removing the front panel and waste fluid containers

24. Safety element:

thermocouple safety feature

25. Safety thermocouple:

Yes

26. Number of burners/hot plates:

1

27. Type of gas cooking zones:

Thales

28. Solid top thickness [mm]:

15

Technical data sheet

Technical parameters



Cooking range solid top gas 1x burner without cabinet

Model	SAP Code	00005858
--------------	-----------------	----------

29. Solid top dimensions [mm x mm]:

370 x 570

31. Solid top ignition:

Piezo + Eternal Flame

30. Solid top material:

chrome-molybdenum