

Technical data sheet



Product features

Meat mincer 1 grinding group 150 kg/h 230 V

Model	SAP Code	00002208
--------------	-----------------	----------



- Composition for meat grinders: Single composition
- Maximal production per hour [kg/h]: 150
- Material: Aluminium
- Diameter of inner matrix [mm]: 6
- Additional information: Noise level 74.4 dB during operation
- Main switch: Yes

SAP Code	00002208	Power electric [kW]	0.370
Net Width [mm]	500	Loading	230 V / 1N - 50 Hz
Net Depth [mm]	280	Maximal production per hour [kg/h]	150
Net Height [mm]	425	Composition for meat grinders	Single composition
Net Weight [kg]	20.00		

Technical data sheet



Technical drawing

Meat mincer 1 grinding group 150 kg/h 230 V

Model

SAP Code

00002208

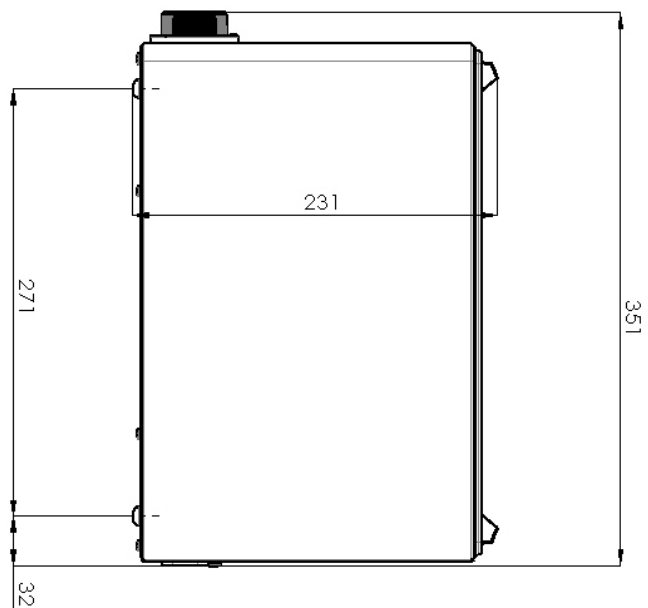
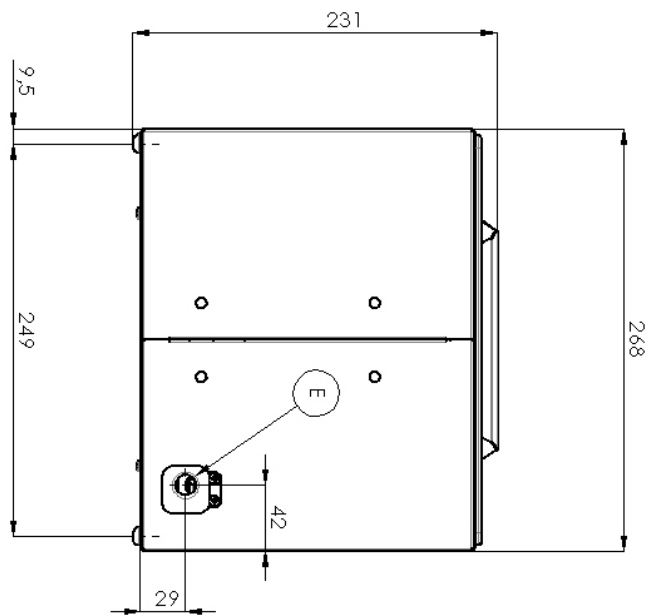

Technical data sheet



Product benefits

Meat mincer 1 grinding group 150 kg/h 230 V

Model

SAP Code

00002208

1

Single composition

simplicity

- suitable for coarser grinding of meat
- very easy to assemble and disassemble thanks to its single composition

2

Reverse gear

possibility to reverse the operation to release the auger

- no need to disassemble the mill when the auger is overloaded
- easy cleaning

3

Production 150 kg/h

large capacity

- great price/performance ratio
- time and cost saving

4

Polycarbonate hopper

I can put it in the dishwasher compared to anodized aluminum

- simplification of cleaning

Technical data sheet



Technical parameters

Meat mincer 1 grinding group 150 kg/h 230 V

Model

SAP Code

00002208

1. SAP Code:

00002208

2. Net Width [mm]:

500

3. Net Depth [mm]:

280

4. Net Height [mm]:

425

5. Net Weight [kg]:

20.00

6. Gross Width [mm]:

500

7. Gross depth [mm]:

300

8. Gross Height [mm]:

500

9. Gross Weight [kg]:

22.00

10. Device type:

Electric unit

11. Material:

Aluminium

12. Device color:

Stainless steel

13. Power electric [kW]:

0.370

14. Loading:

230 V / 1N - 50 Hz

15. Control type:

Mechanical

16. Main switch:

Yes

17. Maximal production per hour [kg/h]:

150

18. Additional information:

Noise level 74.4 dB during operation

19. Composition for meat grinders:

Single composition

20. Diameter of inner matrix [mm]:

6

21. Inverse of device:

Yes