

Technical data sheet

Product features



Cooking range electric 4x plate without cabinet 400 V

Model	SAP Code	00005840
--------------	-----------------	----------



- Device type: Electric unit
- Power consumption of the zone 1 [kW]: 2,6
- Power consumption of the zone 2 [kW]: 2,6
- Power consumption of the zone 3 [kW]: 2,6
- Power consumption of the zone 4 [kW]: 2,6
- Protection of controls: IPX5
- Material: Stainless steel

SAP Code	00005840	Loading	400 V / 3N - 50 Hz
Net Width [mm]	800	Number of zones	4
Net Depth [mm]	705	Power consumption of the zone 1 [kW]	2,6
Net Height [mm]	280	Power consumption of the zone 2 [kW]	2,6
Net Weight [kg]	60.00	Power consumption of the zone 3 [kW]	2,6
Power electric [kW]	10.400	Power consumption of the zone 4 [kW]	2,6

Technical data sheet

Technical drawing



Cooking range electric 4x plate without cabinet 400 V

Model

SAP Code

00005840

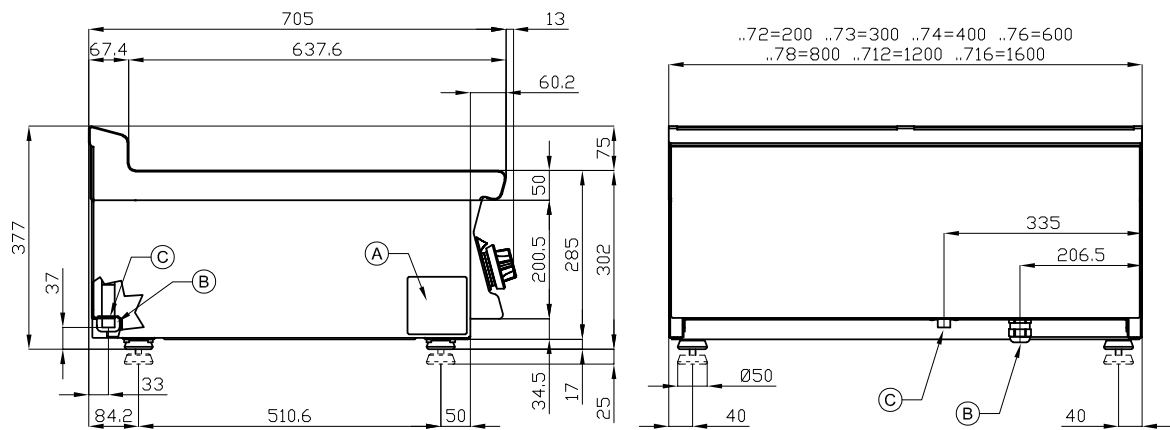

A	Data plate		B	Electrical connection	
---	------------	--	---	-----------------------	--

Technical data sheet

Product benefits



Cooking range electric 4x plate without cabinet 400 V

Model

SAP Code

00005840

1

Square plates

quick warm-up
efficient cooking on a round surface with easy
adhesion to dishes

- time-saving in food preparation
- easy to use thanks to the large surface area of the
cooking plates

2

Internal thermostatic plate protection

longer service life of the plates

- no overheating of the plates and no cracking

3

Degree of protection of the control elements IPX5

maintenance-free system
resistance to splash water
long life

- savings on service interventions
- easy cleaning and maintenance of equipment

4

All-stainless design

the material does not cut
wear resistance of the material
long life

- savings on service interventions
- easy cleaning and maintenance of equipment

5

Hygienic moldings of the top plate

absence of sharp corners and edges (potential places
where dirt could stick)
smooth transitions

- easy quick cleaning

6

Cooking unit for use on a table or on a base

variable use
the possibility of placement in smaller spaces

- easy handling
- cost savings on substructure

7

Square cast iron plates

durable square-shaped cast-iron plates

- larger plates with higher output
- also suitable for atypical vessels

Technical data sheet

Technical parameters



Cooking range electric 4x plate without cabinet 400 V

Model

SAP Code

00005840

1. SAP Code:

00005840

2. Net Width [mm]:

800

3. Net Depth [mm]:

705

4. Net Height [mm]:

280

5. Net Weight [kg]:

60.00

6. Gross Width [mm]:

830

7. Gross depth [mm]:

770

8. Gross Height [mm]:

540

9. Gross Weight [kg]:

66.00

10. Device type:

Electric unit

11. Construction type of device:

Table top

12. Power electric [kW]:

10.400

13. Loading:

400 V / 3N - 50 Hz

27. Service accessibility:

From the front by removing the front panel and waste fluid containers

14. Protection of controls:

IPX5

15. Material:

Stainless steel

16. Worktop type:

Molded - comfortable cleaning maintenance

17. Worktop material:

AISI 304

18. Worktop Thickness [mm]:

2.00

19. Number of zones:

4

20. Power consumption of the zone 1 [kW]:

2,6

21. Power consumption of the zone 2 [kW]:

2,6

22. Power consumption of the zone 3 [kW]:

2,6

23. Power consumption of the zone 4 [kW]:

2,6

24. Maximum device temperature [°C]:

300

25. Minimum device temperature [°C]:

50

26. Number of power control stages:

7

30. Number of burners/hot plates:

4

Technical data sheet

Technical parameters



Cooking range electric 4x plate without cabinet 400 V

Model	SAP Code	00005840
--------------	-----------------	----------

28. Safety element:

internal thermostatic protection of the hotplate
against overheating

31. Type of electric cooking zones:

Squared

29. Safety thermostat:

Yes