

Technical data sheet

Product features



Electric fryer 25+25 l electronic 7” TouchSreen, filtration

Model	SAP Code	00014411
--------------	-----------------	----------



- Basin volume [l]: 25
- Drain type: Trough the cabinet
- Drain: Yes
- Maximum device temperature [°C]: 190
- Minimum device temperature [°C]: 50
- Material: AISI 304
- Number of baskets: 4
- Basket dimensions [mm x mm x mm]: 135x450x150

SAP Code	00014411	Loading	400 V / 3N - 50 Hz
Net Width [mm]	800	Basin volume [l]	25
Net Depth [mm]	900	Number of basins	2
Net Height [mm]	900	Number of baskets	4
Net Weight [kg]	130.00	Basket dimensions [mm x mm x mm]	135x450x150
Power electric [kW]	44.600	Production of fries [kg/h]	70

Technical data sheet

Technical drawing



Electric fryer 25+25 l electronic 7" TouchSreen, filtration

Model

SAP Code

00014411

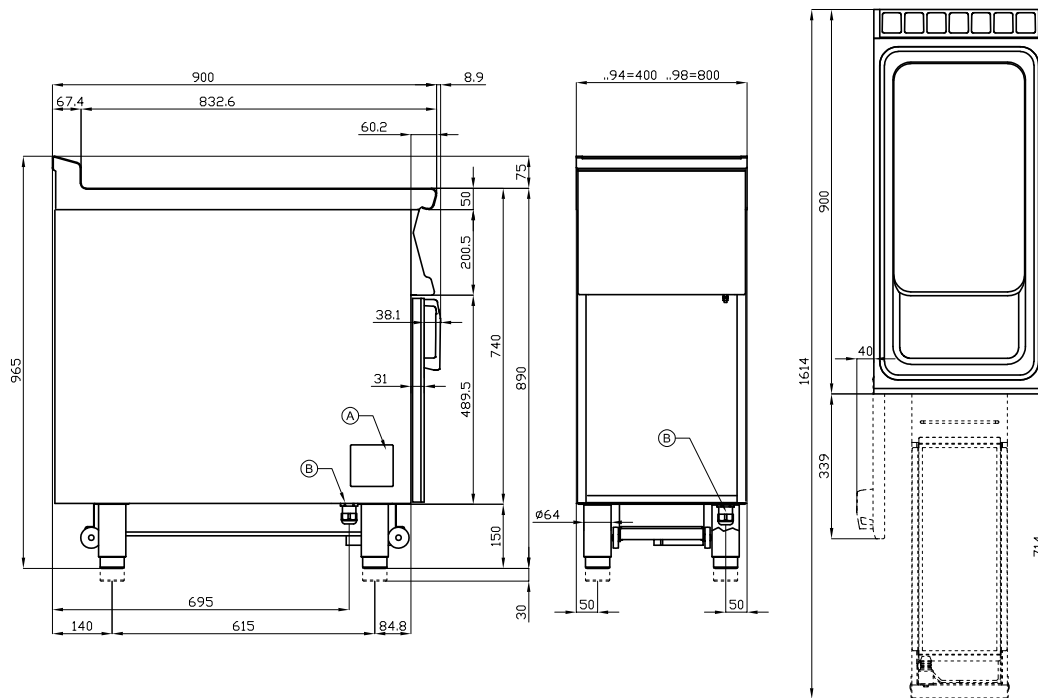

A	Data plate	B	Electrical connection
---	------------	---	-----------------------

Technical data sheet

Technical parameters



Electric fryer 25+25 l electronic 7" TouchSreen, filtration

Model

SAP Code

00014411

1. SAP Code:

00014411

2. Article group:

Fryers

3. Net Width [mm]:

800

4. Net Depth [mm]:

900

5. Net Height [mm]:

900

6. Net Weight [kg]:

130.00

7. Gross Width [mm]:

830

8. Gross depth [mm]:

970

9. Gross Height [mm]:

1110

10. Gross Weight [kg]:

146.00

11. Device type:

Electric unit

12. Construction type of device:

With substructure

13. Power electric [kW]:

44.600

14. Loading:

400 V / 3N - 50 Hz

15. Protection of controls:

IPX5

16. Device color:

Stainless steel

17. Material:

AISI 304

18. Indicators:

operation and warm-up

19. Worktop type:

Molded - comfortable cleaning maintenance

20. Worktop material:

AISI 304

21. Basin volume [l]:

25

22. Basin dimensions [mm x mm x mm]:

310x510x330

23. Maximum device temperature [°C]:

190

24. Minimum device temperature [°C]:

50

25. Safety thermostat:

Yes

26. Adjustable feet:

Yes

27. Heating element material:

AISI 304

28. Number of baskets:

4

Technical data sheet

Technical parameters



Electric fryer 25+25 l electronic 7" TouchSreen, filtration

Model

SAP Code

00014411

29. Number of basins:

2

32. Production of fries [kg/h]:

70

30. Basket dimensions [mm x mm x mm]:

135x450x150

33. Drain type:

Trough the cabinet

31. Basin material:

AISI 304 - High quality stainless steel

34. Drain:

Yes