

# Technical data sheet

## Product features



### Fry-top griddle plate 80x45 gas chromed combined without cabinet

<b>Model</b>	<b>SAP Code</b>	00001063
--------------	-----------------	----------



- Top type: Combined
- Griddle dimensions [mm x mm]: 795 x 450
- Griddle thickness [mm]: 14.00
- Worktop material: Super chrom
- Surface finish: SUPERCHROME - untreated chrome surface
- Ignition: Piezo + večný plamen

<b>SAP Code</b>	00001063	<b>Power gas [kW]</b>	12.000
<b>Net Width [mm]</b>	800	<b>Type of gas</b>	Natural gas, propane butane
<b>Net Depth [mm]</b>	600	<b>Griddle dimensions [mm x mm]</b>	795 x 450
<b>Net Height [mm]</b>	280	<b>Top type</b>	Combined
<b>Net Weight [kg]</b>	72.00		

# Technical data sheet

Technical drawing



## Fry-top griddle plate 80x45 gas chromed combined without cabinet

Model

SAP Code

00001063

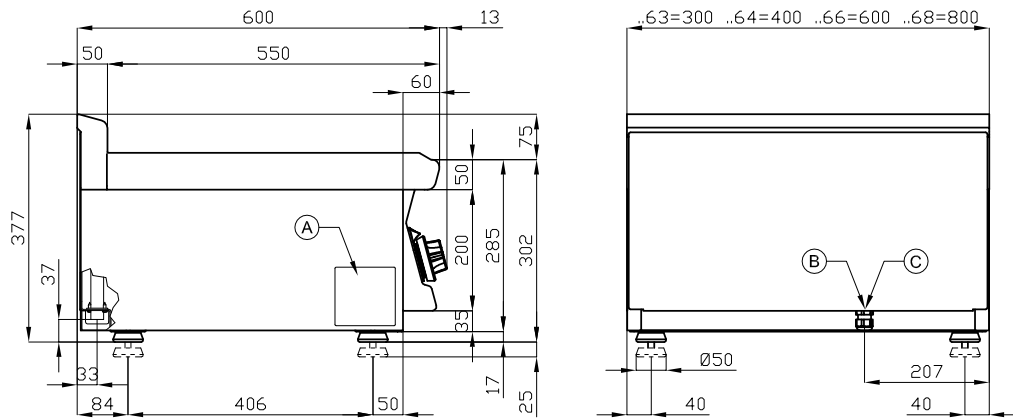

A	Data plate		C	Gas connection	ISO 7-1 1/2" M
---	------------	--	---	----------------	----------------

# Technical data sheet

## Product benefits



### Fry-top griddle plate 80x45 gas chromed combined without cabinet

Model

SAP Code

00001063

1

#### Safety element – thermocouple

safe service for staff  
there is no unnecessary gas leakage  
long life

- savings on service interventions
- easier and faster operation

2

#### All-stainless design

long life  
resistance of AISI 304 stainless steel material  
the material does not cut

- savings on service interventions
- easy cleaning and maintenance of equipment

3

#### Degree of protection of the control elements IPX5

maintenance-free system  
resistance to splash water  
long life

- savings on service interventions
- easy cleaning and maintenance of equipment

4

#### Outlet for waste liquids

ensures that oil drips into the socket

- easy maintenance
- easy cleaning

5

#### High detachable hem

better hygienic conditions  
preventing grease from splashing onto ancillary equipment

- easy maintenance
- easy cleaning

6

#### Combined plate made of chrome-plated steel

the product bakes less  
enables preparation on smooth or grooved plates

- time-saving in food preparation
- easy preparation of different types of dishes

7

#### Outlet for waste liquids

ensures that oil drips into the socket

- easy maintenance
- easy cleaning

8

#### Cooking unit for use on a table or on a base

variable use  
the possibility of placement in smaller spaces

- easy handling
- cost savings on substructure

# Technical data sheet

Technical parameters



## Fry-top griddle plate 80x45 gas chromed combined without cabinet

Model

SAP Code

00001063

**1. SAP Code:**

00001063

**2. Net Width [mm]:**

800

**3. Net Depth [mm]:**

600

**4. Net Height [mm]:**

280

**5. Net Weight [kg]:**

72.00

**6. Gross Width [mm]:**

830

**7. Gross depth [mm]:**

690

**8. Gross Height [mm]:**

610

**9. Gross Weight [kg]:**

83.00

**10. Device type:**

Gas unit

**11. Construction type of device:**

Table top

**12. Power gas [kW]:**

12.000

**13. Ignition:**

Piezo + večný plamen

**14. Type of gas:**

Natural gas, propane butane

**15. Protection of controls:**

IPX5

**16. Device color:**

Stainless steel

**17. Material:**

AISI 304 top plate and cladding

**18. Worktop material:**

Super chrom

**19. Worktop Thickness [mm]:**

2.50

**20. Surface finish:**

SUPERCHROME - untreated chrome surface

**21. Service accessibility:**

Trough the frontal panel

**22. Safety thermocouple:**

Yes

**23. Adjustable feet:**

Yes

**24. Griddle dimensions [mm x mm]:**

795 x 450

**25. Griddle thickness [mm]:**

14.00

**26. Top type:**

Combinated