

Technical data sheet

Product features



Bain marie gas 2x GN 1/1 + 1/3 - 150 with cabinet

Model	SAP Code	00005919
--------------	-----------------	----------



- Water inlet: mechanical tap
- Drain type: Trough the cabinet
- Drain: Yes
- Material: AISI 304
- Protection of controls: IPX5
- Ignition: Piezo+večný plamen

SAP Code	00005919	Power gas [kW]	6.500
Net Width [mm]	800	Type of gas	Natural Gas
Net Depth [mm]	900	Number of GN / EN	4
Net Height [mm]	900	GN / EN size in device	GN 1/1 + GN 1/3
Net Weight [kg]	71.00	GN device depth	150

Technical data sheet

Technical drawing



Bain marie gas 2x GN 1/1 + 1/3 - 150 with cabinet

Model

SAP Code

00005919

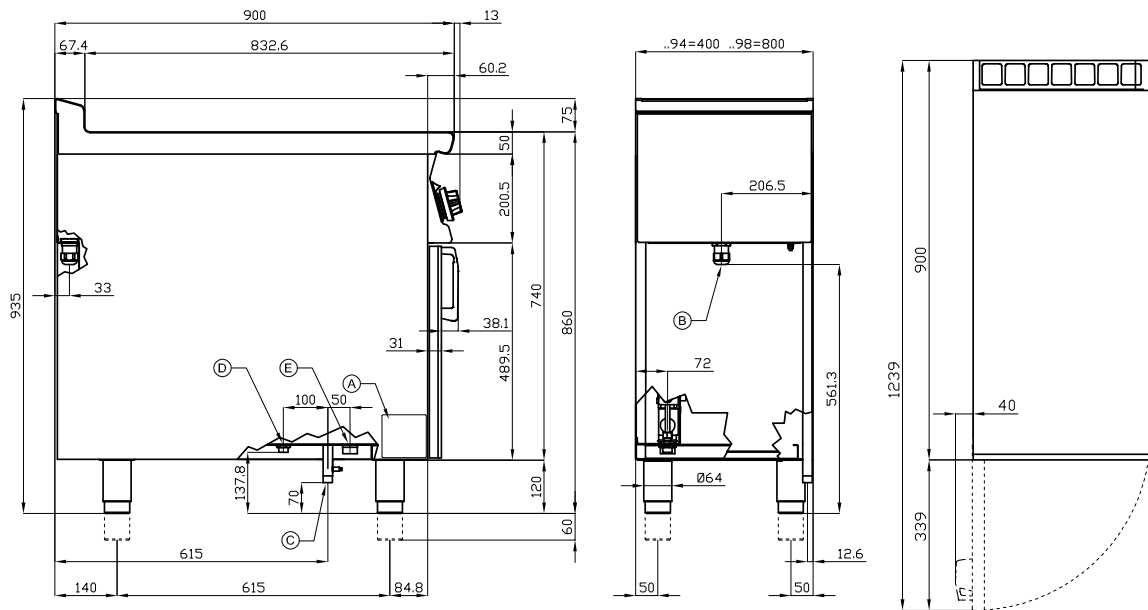

A	Data plate		C	Gas connection	ISO 7-1 1/2" M
D	Cold water connection	ISO 7-1 1/2" M	E	Water drainage	ISO 7-1 1" M

Technical data sheet

Product benefits



Bain marie gas 2x GN 1/1 + 1/3 - 150 with cabinet

Model

SAP Code

00005919

1

Deep-draft bathtubs

basins without sharp transitions, edges and corners

- easy maintenance
- perfect sanitation

2

Controlling each bath separately

variability of use

- possibility to keep different foods at different temperatures

3

All-stainless steel construction

harmless to health for contact with food
robustness

- perfect sanitation
- long service life

4

Drain valve with snap-on elbow for easy draining

safer placement of the drain valve

- valve location and use of an elbow and safety lock prevent unintentional contact and possible scalding

Technical data sheet

Technical parameters



Bain marie gas 2x GN 1/1 + 1/3 - 150 with cabinet

Model

SAP Code

00005919

1. SAP Code:

00005919

2. Net Width [mm]:

800

3. Net Depth [mm]:

900

4. Net Height [mm]:

900

5. Net Weight [kg]:

71.00

6. Gross Width [mm]:

830

7. Gross depth [mm]:

970

8. Gross Height [mm]:

1110

9. Gross Weight [kg]:

81.00

10. Device type:

Gas unit

11. Construction type of device:

With substructure

12. Power gas [kW]:

6.500

13. Ignition:

Piezo+večný plamen

14. Type of gas:

Natural Gas

15. Protection of controls:

IPX5

16. Device color:

Stainless steel

17. Material:

AISI 304

18. Indicators:

operation and warm-up

19. Worktop type:

Molded - comfortable cleaning maintenance

20. Safety thermocouple:

Yes

21. Adjustable feet:

Yes

22. Heating element material:

AISI 304

23. Water inlet:

mechanical tap

24. Drain type:

Trough the cabinet

25. Drain:

Yes

26. Number of GN / EN:

4

27. GN / EN size in device:

GN 1/1 + GN 1/3

28. GN device depth:

150