

Technical data sheet



Product features

Combi convection steam oven electric 5x GN 2/3 electromechanical, direct steam 230 V

| | | |
|--------------|-----------------|----------|
| Model | SAP Code | 00011340 |
|--------------|-----------------|----------|



- Steam type: Injection
- Number of GN / EN: 5
- GN / EN size in device: GN 2/3
- GN device depth: 65
- Control type: Mechanical
- Humidity control: No
- Advanced moisture adjustment: No
- Delta T heat preparation: Yes
- Multi level cooking: No
- Door constitution: Vented safety double glass, removable for easy cleaning

| | | | |
|----------------------------|----------|-------------------------------|--------------------|
| SAP Code | 00011340 | Loading | 230 V / 1N - 50 Hz |
| Net Width [mm] | 600 | Steam type | Injection |
| Net Depth [mm] | 690 | Number of GN / EN | 5 |
| Net Height [mm] | 670 | GN / EN size in device | GN 2/3 |
| Net Weight [kg] | 52.00 | GN device depth | 65 |
| Power electric [kW] | 3.300 | Control type | Mechanical |

Technical data sheet



Technical drawing

Combi convection steam oven electric 5x GN 2/3 electromechanical, direct steam 230 V

Model

SAP Code

00011340

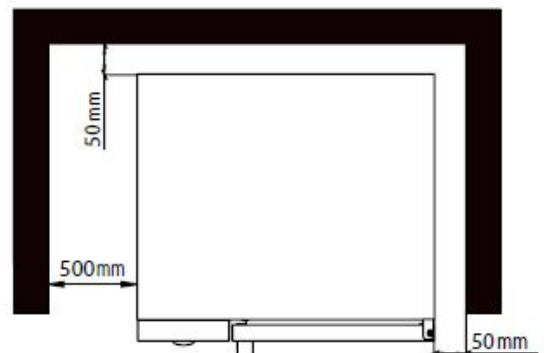
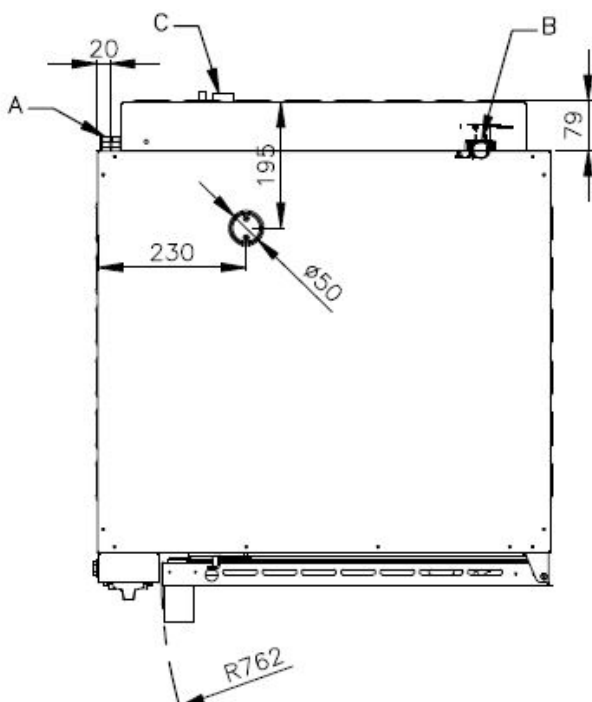
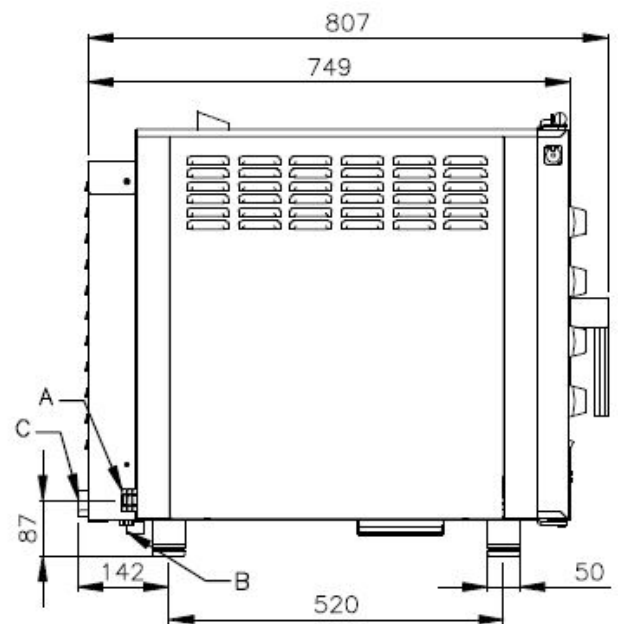
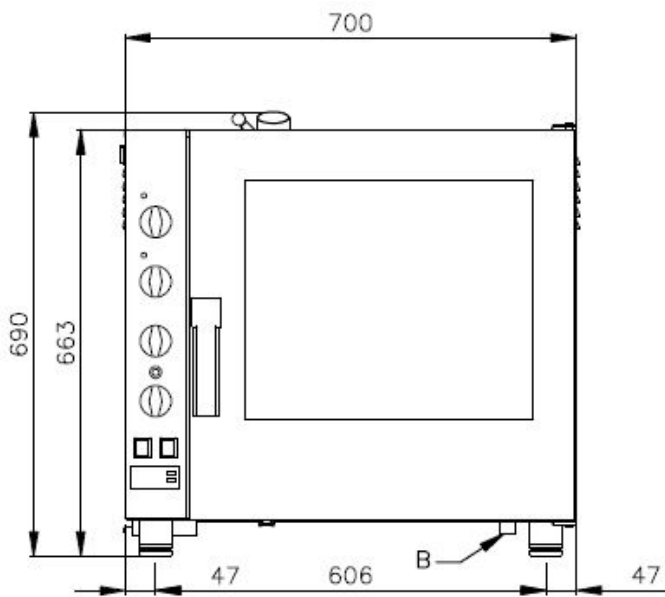

Technical data sheet



Product benefits

Combi convection steam oven electric 5x GN 2/3 electromechanical, direct steam 230 V

Model

SAP Code

00011340

1

Direct injection

steam generation by spraying water on the heating elements directly in the chamber

- simple and efficient solution
- moist steam with water droplets

2

Manual controls

setting values using rotary knobs

- suitable for roasting
- easy to use even for non-technical operators

3

A kit of two machines on top of each other

connection kit allowing two machines to be placed on top of each other
connects the connections, inlets, wastes and ventilation of the lower combi oven

- allows the user to place two machines in smaller spaces to increase production; the chef can prepare two different dishes simultaneously

4

Temperature range 30°C - 300°C

heating the chamber in the temperature range of 30 to 300 °C

- Possibility to prepare a large variety of dishes, from low-temperature baking to grilling, gratinating, etc.

5

Stainless steel construction

construction material is high quality stainless steel ensuring long life
high hygiene standard

- safe food preparation; long service life; easy cleaning

Technical data sheet



Technical parameters

Combi convection steam oven electric 5x GN 2/3 electromechanical, direct steam 230 V

Model

SAP Code

00011340

1. SAP Code:

00011340

2. Net Width [mm]:

600

3. Net Depth [mm]:

690

4. Net Height [mm]:

670

5. Net Weight [kg]:

52.00

6. Gross Width [mm]:

810

7. Gross depth [mm]:

700

8. Gross Height [mm]:

780

9. Gross Weight [kg]:

60.00

10. Device type:

Electric unit

11. Power electric [kW]:

3.300

12. Loading:

230 V / 1N - 50 Hz

13. Material:

AISI 304

14. Device color:

Stainless steel

15. Adjustable feet:

Yes

16. Humidity control:

No

17. Stacking availability:

Yes

18. Control type:

Mechanical

19. Additional information:

possibility of reverse door opening - handle on the right side (must be specified when ordering)

20. Steam type:

Injection

21. Sturdier version:

No

22. Chimney for moisture extraction:

Yes

23. Delta T heat preparation:

Yes

24. Cold smoke-dry function:

No

25. Unified finishing of meals EasyService:

No

26. Night cooking:

No

27. Multi level cooking:

No

28. Advanced moisture adjustment:

No

Technical data sheet



Technical parameters

Combi convection steam oven electric 5x GN 2/3 electromechanical, direct steam 230 V

Model

SAP Code

00011340

29. Slow cooking:

No

30. Fan stop:

Interruption when door is opened, not braked

31. Lighting type:

LED lighting in the door, on one side

32. Cavity material and shape:

AISI 304, with rounded corners for easy cleaning

33. Reversible fan:

Yes

34. Sustaince box:

Yes

35. Heating element material:

Incoloy

36. Probe:

No

37. Distance between the layers [mm]:

74

38. Smoke-dry function:

No

39. Interior lighting:

Yes

40. Low temperature heat treatment:

No

41. Number of fans:

1

42. Number of fan speeds:

2

43. USB port:

No

44. Door constitution:

Vented safety double glass, removable for easy cleaning

45. Minimum device temperature [°C]:

50

46. Maximum device temperature [°C]:

280

47. Device heating type:

Combination of steam and hot air

48. HACCP:

Yes

49. Number of GN / EN:

5

50. GN / EN size in device:

GN 2/3

51. GN device depth:

65

52. Food regeneration:

Yes