

# Technical data sheet



## Product features

<b>Model</b>	<b>SAP Code</b>	00110121
SPT 70/80 21 E	<b>A group of articles - web</b>	Stoves



- Device type: Electric unit
- Power consumption of the zone 1 [kW]: 2,6
- Power consumption of the zone 2 [kW]: 2,6
- Power consumption of the zone 3 [kW]: 2,6
- Power consumption of the zone 4 [kW]: 2,6
- Type of internal part of the appliance 1 (eg oven): Electric
- Type of internal part of the appliance 2 (eg oven): Static
- Protection of controls: IPX4
- Material: AISI 304 top plate, AISI 430 cladding

<b>SAP Code</b>	00110121	<b>Power consumption of the zone 2 [kW]</b>	2,6
<b>Net Width [mm]</b>	800	<b>Power consumption of the zone 3 [kW]</b>	2,6
<b>Net Depth [mm]</b>	700	<b>Power consumption of the zone 4 [kW]</b>	2,6
<b>Net Height [mm]</b>	900	<b>Type of internal part of the appliance 1 (eg oven)</b>	Electric
<b>Net Weight [kg]</b>	89.00	<b>Type of internal part of the appliance 2 (eg oven)</b>	Static
<b>Power electric [kW]</b>	16.700	<b>Width of internal part [mm]</b>	682
<b>Loading</b>	400 V / 3N - 50 Hz	<b>Depth of internal part [mm]</b>	558
<b>Number of zones</b>	4	<b>Height of internal part [mm]</b>	348
<b>Power consumption of the zone 1 [kW]</b>	2,6	<b>Diameter of device [mm]</b>	220

# Technical data sheet



Technical drawing

<b>Model</b>	<b>SAP Code</b>	00110121
SPT 70/80 21 E	<b>A group of articles - web</b>	Stoves

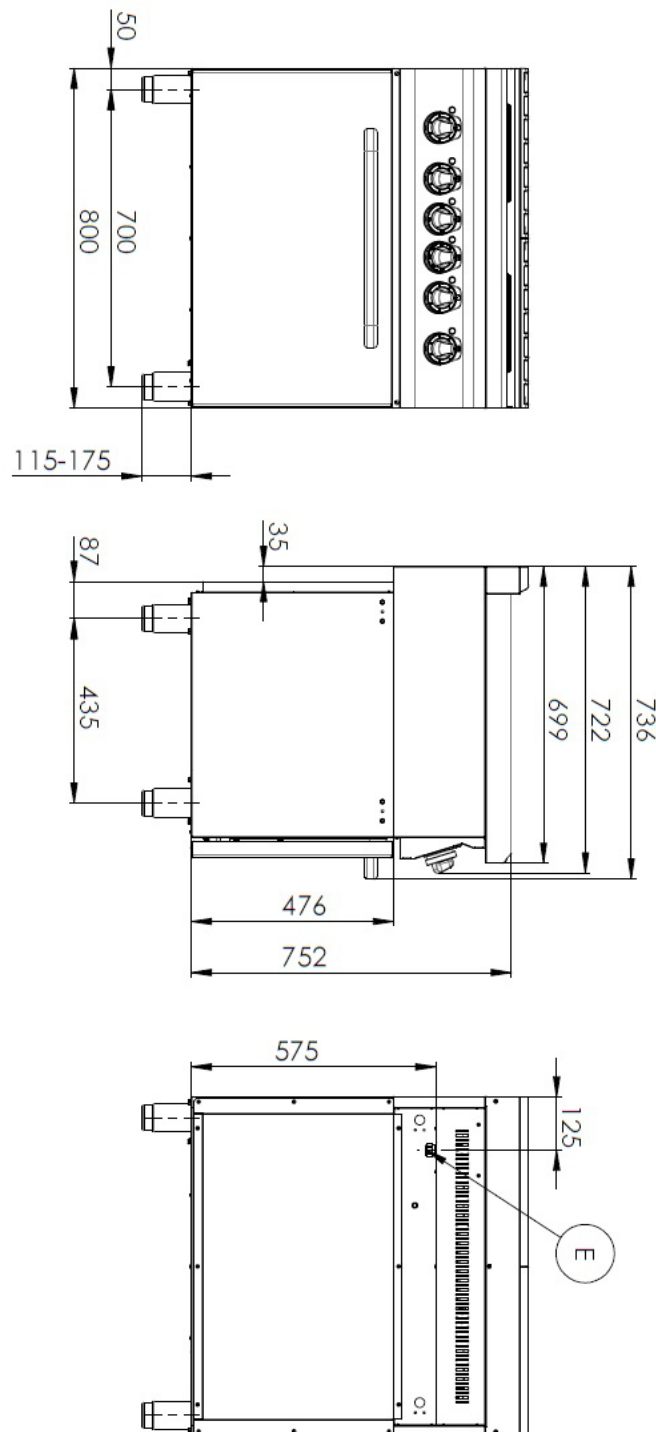

<b>Model</b>	<b>SAP Code</b>	00110121
SPT 70/80 21 E	<b>A group of articles - web</b>	Stoves

- 1 Round plates**  
quick warm-up  
efficient cooking on a round surface with easy adhesion to dishes
- time-saving in food preparation
  - easy to use thanks to the large surface area of the cooking plates

- 2 Internal thermostatic plate protection**  
longer service life of the plates
- no overheating of the plates and no cracking

- 3 Degree of protection of the control elements IPX4**  
maintenance-free system  
resistance to splash water  
long life
- savings on service interventions
  - easy cleaning and maintenance of equipment

- 4 All-stainless design**  
long life  
resistance of a ground steel plate with a thickness of 10 mm
- savings on service interventions
  - higher corrosion resistance

- 5 Hygienic moldings of the top plate**  
absence of sharp corners and edges (potential places where dirt could stick)  
smooth transitions
- easy quick cleaning

- 6 Large electric oven with four positions for racks with static cooking**  
static baking  
high capacity and variability  
all-stainless design
- suitable for yeast dishes and desserts
  - long service life
  - easy to clean

# Technical data sheet



## Technical parameters

<b>Model</b>	<b>SAP Code</b>	00110121
SPT 70/80 21 E	<b>A group of articles - web</b>	Stoves

**1. SAP Code:**

00110121

**2. Article group:**

RF-Line 700

**3. Net Width [mm]:**

800

**4. Net Depth [mm]:**

700

**5. Net Height [mm]:**

900

**6. Net Weight [kg]:**

89.00

**7. Gross Width [mm]:**

840

**8. Gross depth [mm]:**

800

**9. Gross Height [mm]:**

975

**10. Gross Weight [kg]:**

102.00

**11. Device type:**

Electric unit

**12. Construction type of device:**

With substructure

**13. Power electric [kW]:**

16.700

**14. Loading:**

400 V / 3N - 50 Hz

**15. Protection of controls:**

IPX4

**16. Device color:**

Stainless steel

**17. Material:**

AISI 304 top plate, AISI 430 cladding

**18. Worktop type:**

Molded - comfortable cleaning maintenance

**19. Worktop material:**

AISI 304

**20. Worktop Thickness [mm]:**

1.20

**21. Number of zones:**

4

**22. Power consumption of the zone 1 [kW]:**

2,6

**23. Power consumption of the zone 2 [kW]:**

2,6

**24. Power consumption of the zone 3 [kW]:**

2,6

**25. Power consumption of the zone 4 [kW]:**

2,6

**26. Number of power control stages:**

6

**27. Adjustable feet:**

Yes

**28. Number of burners/hot plates:**

4

**29. Diameter of device [mm]:**

220

**30. Type of electric cooking zones:**

Oval

**31. Oven Type:**

electrical static

**32. Oven power electric [kW]:**

6.30

# Technical data sheet



## Technical parameters

<b>Model</b>	<b>SAP Code</b>	00110121
SPT 70/80 21 E	<b>A group of articles - web</b>	Stoves

**33. Oven size:**

GN 2/1

**34. Type of internal part of the appliance 1 (eg oven):**

Electric

**35. Type of internal part of the appliance 2 (eg oven):**

Static

**36. Width of internal part [mm]:**

682

**37. Depth of internal part [mm]:**

558

**38. Height of internal part [mm]:**

348

**39. Maximum temperature of the inner chamber [°C]:**

300

**40. Minimum temperature of the inner chamber [°C]:**

50

**41. Number of internal parts:**

4