

# Technical data sheet



## Product features

### Food display island chilled GN 6-1/1 Wenge

<b>Model</b>	<b>SAP Code</b>	00012105
--------------	-----------------	----------



- Buffet type: BLUE
- Device properties: Chilled
- Number of GN / EN: 6
- GN / EN size in device: GN 1/1
- GN device depth: 150
- Minimum device temperature [°C]: 4
- Maximum device temperature [°C]: 8

<b>SAP Code</b>	00012105	<b>Loading</b>	230 V / 1N - 50 Hz
<b>Net Width [mm]</b>	2144	<b>Number of GN / EN</b>	6
<b>Net Depth [mm]</b>	760	<b>GN / EN size in device</b>	GN 1/1
<b>Net Height [mm]</b>	1288	<b>GN device depth</b>	150
<b>Net Weight [kg]</b>	199.80	<b>Minimum device temperature [°C]</b>	4
<b>Power electric [kW]</b>	0.494	<b>Maximum device temperature [°C]</b>	8

# Technical data sheet



Technical drawing

Food display island chilled GN 6-1/1 Wenge

Model

SAP Code

00012105

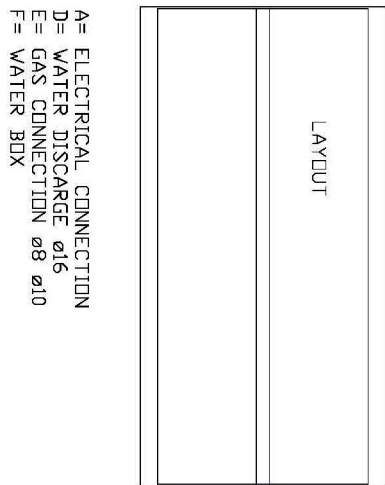

A= ELECTRICAL CONNECTION  
 D= WATER DISCHARGE ø16  
 E= GAS CONNECTION ø8 ø10  
 F= WATER BOX

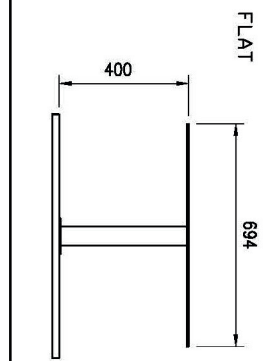
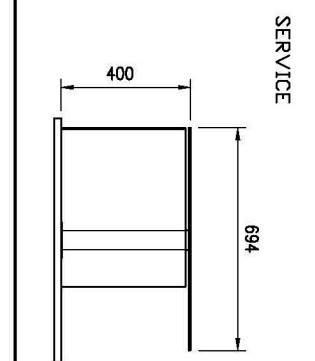
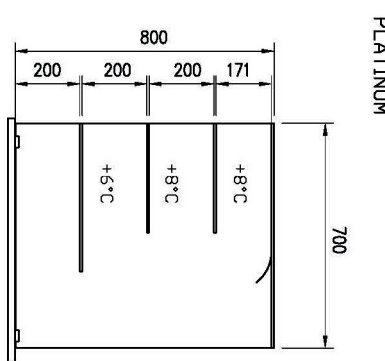
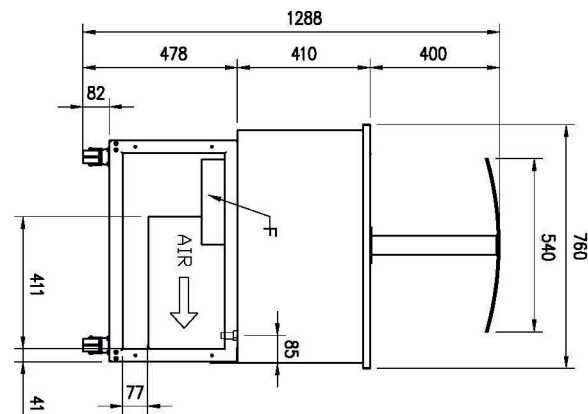
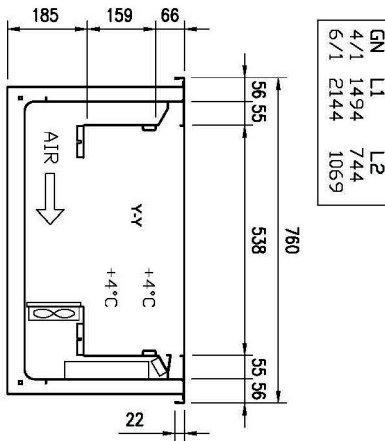
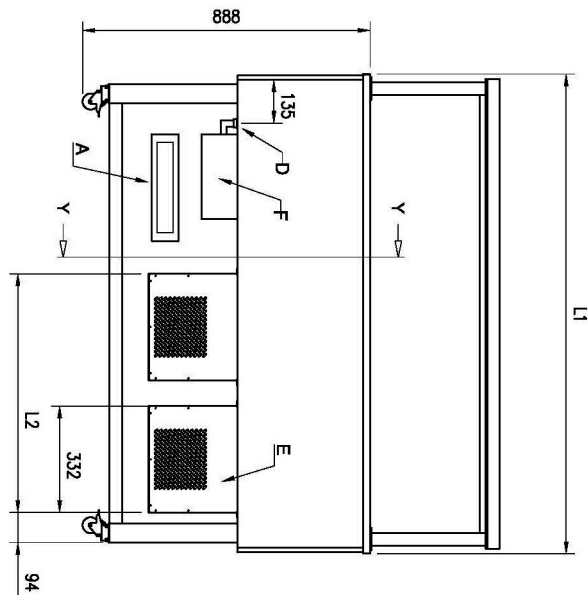

### Food display island chilled GN 6-1/1 Wenge

Model

SAP Code

00012105

1

#### Dynamic cooling

- constant temperature in all places of the refrigerated space
- greater hygienic safety of chilled food

2

#### Breathing screen with electric drive

- the possibility of easily covering the food
- higher hygienic safety
  - ease of use
  - attractiveness

3

#### LED lighting

- minimal energy consumption
- economical lighting
  - attractive appearance

4

#### Removable evaporator filter

- easy disassembly
- time saving for cleaning

5

#### All-stainless steel construction

- harmless to health for contact with food  
robustness
- perfect sanitation
  - long service life

6

#### Rounded corners

- basins without sharp edges and corners
- higher hygienic safety
  - time saving due to easy cleaning

7

#### GN insertion up to 15mm

- variability of use
- possibility of cooling different types of food and larger volumes
  - saving time, space, costs

8

#### Travel wheels

- portable buffet table
- greater flexibility in dispensing
  - possibility of use at banquets
  - easier and safer handling

9

#### Breathing galley with trigger

- galerka made of hygienic Plexiglas with motorized displacement
- hygienic food protection
  - the possibility of sealing before dispensing - extending the shelf life of food

# Technical data sheet



## Technical parameters

### Food display island chilled GN 6-1/1 Wenge

<b>Model</b>	<b>SAP Code</b>	00012105
--------------	-----------------	----------

**1. SAP Code:**

00012105

**2. Net Width [mm]:**

2144

**3. Net Depth [mm]:**

760

**4. Net Height [mm]:**

1288

**5. Net Weight [kg]:**

199.80

**6. Gross Width [mm]:**

2208

**7. Gross depth [mm]:**

1012

**8. Gross Height [mm]:**

1100

**9. Gross Weight [kg]:**

220.00

**10. Device type:**

Electric unit

**11. Buffet type:**

BLUE

**12. Device properties:**

Chilled

**13. Device color:**

Hemlock

**14. Power electric [kW]:**

0.494

**15. Loading:**

230 V / 1N - 50 Hz

**16. Number of GN / EN:**

6

**17. GN / EN size in device:**

GN 1/1

**18. GN device depth:**

150

**19. Minimum device temperature [°C]:**

4

**20. Maximum device temperature [°C]:**

8