

Technical data sheet

Product features



Bain marie gas GN 2/1 - 150 with cabinet

Model	SAP Code	00000071
--------------	-----------------	----------



- Water inlet: mechanical tap
- Drain type: Through the substructure with connection to waste
- Drain: Yes
- Safety drain: Yes
- Material: Stainless steel
- Protection of controls: IPX5
- Ignition: Piezo+večný plamen

SAP Code	00000071	Power gas [kW]	6.500
Net Width [mm]	800	Type of gas	Natural Gas
Net Depth [mm]	705	Number of GN / EN	1
Net Height [mm]	900	GN / EN size in device	GN 2/1
Net Weight [kg]	58.00	GN device depth	150

Technical data sheet

Technical drawing



Bain marie gas GN 2/1 - 150 with cabinet

Model

SAP Code

00000071

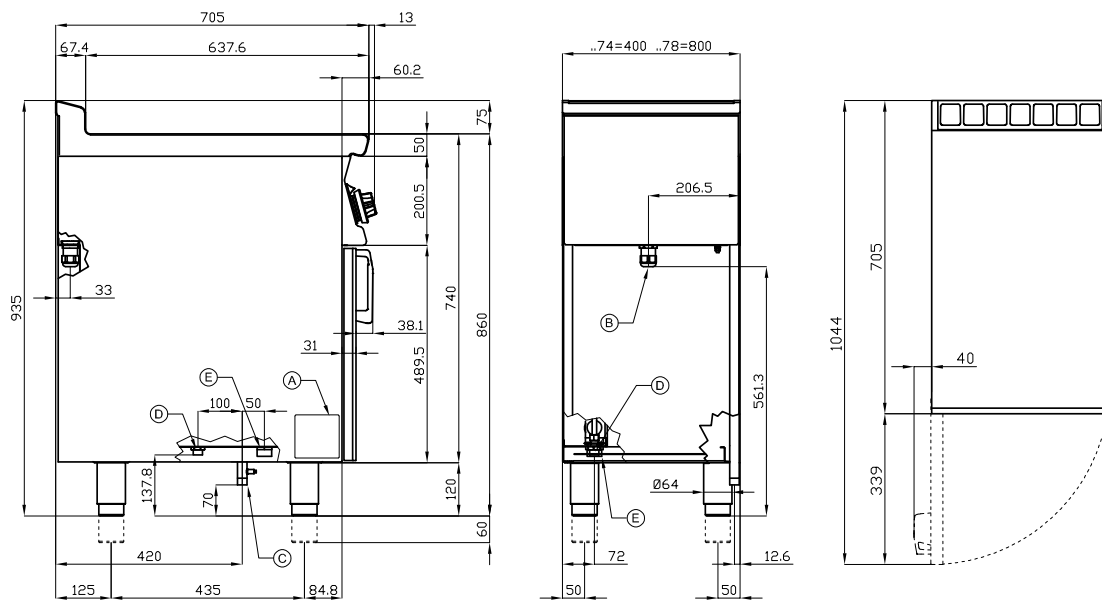

A	Data plate		C	Gas connection	ISO 7-1 1/2" M
D	Cold water connection	ISO 7-1 1/2" M	E	Water drainage	ISO 7-1 1" M

Technical data sheet

Product benefits



Bain marie gas GN 2/1 - 150 with cabinet

Model

SAP Code

0000071

1

Deep-draft bathtubs

basins without sharp transitions, edges and corners

- easy maintenance
- perfect sanitation

2

All-stainless steel construction

harmless to health for contact with food
robustness

- perfect sanitation
- long service life

3

Drain valve with snap-on elbow for easy draining

safer placement of the drain valve

- valve location and use of an elbow and safety lock
prevent unintentional contact and possible scalding

4

Controlling each bath separately

variability of use

- possibility to keep different foods at different
temperatures

Technical data sheet

Technical parameters



Bain marie gas GN 2/1 - 150 with cabinet

Model

SAP Code

0000071

1. SAP Code:

0000071

2. Net Width [mm]:

800

3. Net Depth [mm]:

705

4. Net Height [mm]:

900

5. Net Weight [kg]:

58.00

6. Gross Width [mm]:

830

7. Gross depth [mm]:

770

8. Gross Height [mm]:

1110

9. Gross Weight [kg]:

68.00

10. Device type:

Gas unit

11. Construction type of device:

With substructure

12. Power gas [kW]:

6.500

13. Ignition:

Piezo+večný plamen

14. Type of gas:

Natural Gas

15. Protection of controls:

IPX5

16. Material:

Stainless steel

17. Indicators:

operation and warm-up

18. Drain valve diameter:

3/4"

19. Worktop type:

Molded - comfortable cleaning maintenance

20. Power control type:

thermostat

21. Service accessibility:

Trough the frontal panel

22. Safety element:

safety element – thermocouple
outlet safety fuse

23. Safety thermocouple:

Yes

24. Adjustable feet:

Yes

25. Additional information:

lid and gastro utensils are not included in the package
door not included can be purchased

26. Number of basins:

1

Technical data sheet

Technical parameters



Bain marie gas GN 2/1 - 150 with cabinet

Model

SAP Code

0000071

27. Water inlet:

mechanical tap

31. Number of GN / EN:

1

28. Drain type:

Through the substructure with connection to waste

32. GN / EN size in device:

GN 2/1

29. Drain:

Yes

33. GN device depth:

150

30. Safety drain:

Yes

34. Drain connection:

Yes