

# Technical data sheet

## Product features



### Fry-top griddle plate 80x45 electric chromed grooved without cabinet 400 V

<b>Model</b>	<b>SAP Code</b>	00001134
--------------	-----------------	----------



- Top type: Grooved
- Griddle dimensions [mm x mm]: 795 x 450
- Griddle thickness [mm]: 14.00
- Worktop material: Super chrom
- Maximum device temperature [°C]: 300

<b>SAP Code</b>	00001134	<b>Power electric [kW]</b>	9.000
<b>Net Width [mm]</b>	800	<b>Loading</b>	400 V / 3N - 50 Hz
<b>Net Depth [mm]</b>	600	<b>Griddle dimensions [mm x mm]</b>	795 x 450
<b>Net Height [mm]</b>	280	<b>Top type</b>	Grooved
<b>Net Weight [kg]</b>	72.00		

# Technical data sheet

Technical drawing



**Fry-top griddle plate 80x45 electric chromed grooved without cabinet 400 V**

**Model**

**SAP Code**

00001134

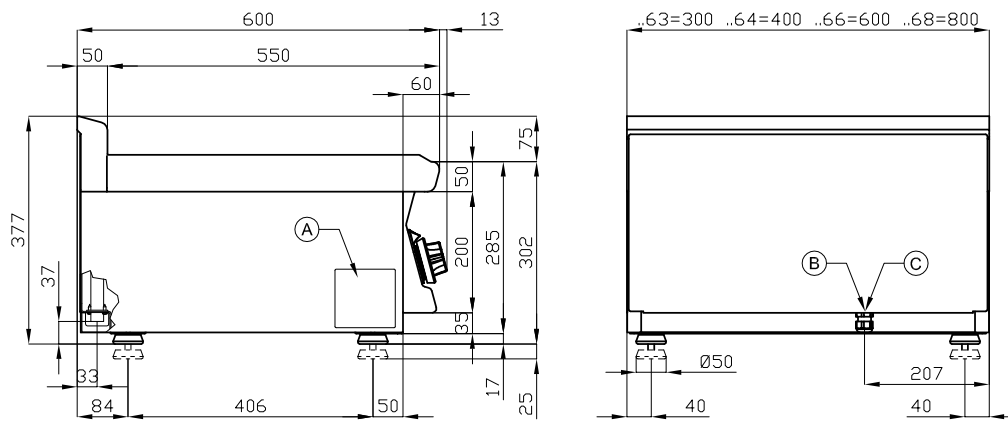

A	Data plate		B	Electrical connection	
---	------------	--	---	-----------------------	--

# Technical data sheet

## Product benefits



### Fry-top griddle plate 80x45 electric chromed grooved without cabinet 400 V

Model

SAP Code

00001134

1

#### All-stainless design

long life  
resistance of AISI 304 stainless steel material  
the material does not cut

- savings on service interventions
- easier and faster operation

2

#### Degree of protection of the control elements IPX5

maintenance-free system  
resistance to splash water  
long life

- savings on service interventions
- easy cleaning and maintenance of equipment

3

#### Outlet for waste liquids

ensures that oil drips into the socket

- easy maintenance
- easy cleaning

4

#### High detachable hem

better hygienic conditions  
preventing grease from splashing onto  
ancillary equipment

- easy maintenance
- easy cleaning

5

#### Grooved plate made of chrome-plated steel

the product bakes less and is easier to clean  
a good warming of the meat with a groove

- time-saving in food preparation
- easy preparation of good-looking food

6

#### Cooking unit for use on a table or on a base

variable use  
the possibility of placement in smaller spaces

- easy handling
- cost savings on substructure

# Technical data sheet

Technical parameters



## Fry-top griddle plate 80x45 electric chromed grooved without cabinet 400 V

**Model**

**SAP Code**

00001134

**1. SAP Code:**

00001134

**2. Net Width [mm]:**

800

**3. Net Depth [mm]:**

600

**4. Net Height [mm]:**

280

**5. Net Weight [kg]:**

72.00

**6. Gross Width [mm]:**

830

**7. Gross depth [mm]:**

690

**8. Gross Height [mm]:**

610

**9. Gross Weight [kg]:**

81.00

**10. Device type:**

Electric unit

**11. Construction type of device:**

Table top

**12. Power electric [kW]:**

9.000

**13. Loading:**

400 V / 3N - 50 Hz

**14. Protection of controls:**

IPX5

**15. Device color:**

Stainless steel

**16. Material:**

AISI 304 top plate and cladding

**17. Indicators:**

operation and warm-up

**18. Worktop material:**

Super chrom

**19. Worktop Thickness [mm]:**

2.50

**20. Maximum device temperature [°C]:**

300

**21. Minimum device temperature [°C]:**

50

**22. Service accessibility:**

Trough the frontal panel

**23. Safety thermostat:**

Yes

**24. Adjustable feet:**

Yes

**25. Griddle dimensions [mm x mm]:**

795 x 450

**26. Griddle thickness [mm]:**

14.00

**27. Top type:**

Grooved