

Technical data sheet



Product features

Cooking range combined with electric convection oven GN 1/1 - 4x burner

Model	SAP Code	00002053
--------------	-----------------	----------



- Device type: Combined unit
- Power consumption of the zone 1 [kW]: 4,5
- Power consumption of the zone 2 [kW]: 4,5
- Power consumption of the zone 3 [kW]: 4,5
- Power consumption of the zone 4 [kW]: 4,5
- Type of internal part of the appliance 1 (eg oven): Electric
- Type of internal part of the appliance 2 (eg oven): Hot air
- Protection of controls: IPX4
- Material: AISI 304 top plate, AISI 430 cladding

SAP Code	00002053	Power consumption of the zone 1 [kW]	4,5
Net Width [mm]	658	Power consumption of the zone 2 [kW]	4,5
Net Depth [mm]	609	Power consumption of the zone 3 [kW]	4,5
Net Height [mm]	900	Power consumption of the zone 4 [kW]	4,5
Net Weight [kg]	65.00	Type of internal part of the appliance 1 (eg oven)	Electric
Power electric [kW]	3.130	Type of internal part of the appliance 2 (eg oven)	Hot air
Loading	230 V / 1N - 50 Hz	Width of internal part [mm]	548
Power gas [kW]	18.000	Depth of internal part [mm]	360
Type of gas	Natural gas, propane butane	Height of internal part [mm]	338
Number of zones	4		

Technical data sheet



Technical drawing

Cooking range combined with electric convection oven GN 1/1 - 4x burner

Model

SAP Code

00002053

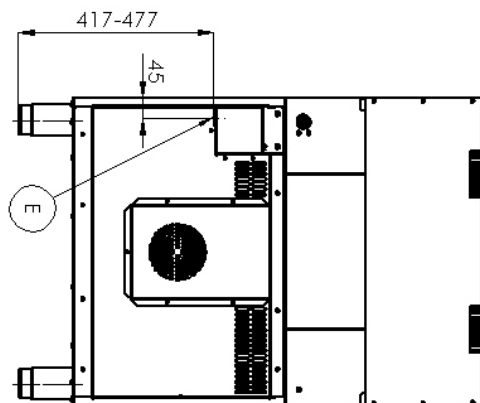
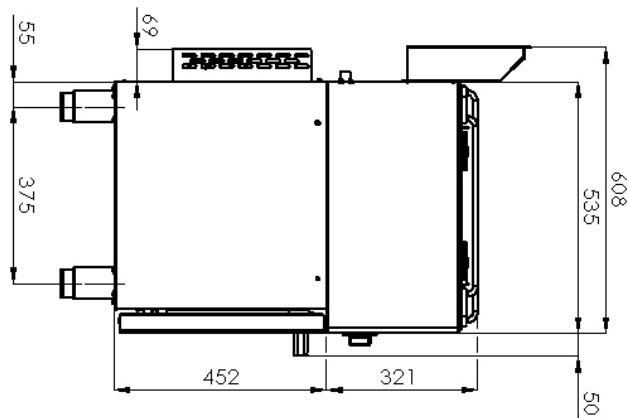
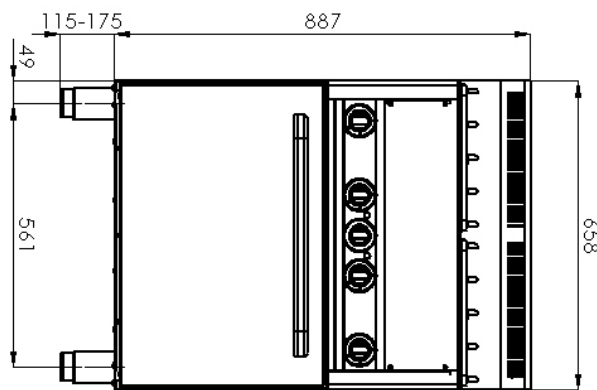

Technical data sheet



Product benefits

Cooking range combined with electric convection oven GN 1/1 - 4x burner

Model	SAP Code	00002053
--------------	-----------------	----------

1

Centered high performance burners

- high performance and efficiency
- brass removable burners
- long life
- detachable
 - energy saving (perfect combustion)
 - time saving for food preparation
 - easy maintenance/cleaning

2

Hygienic moldings of the top plate

- absence of sharp corners and edges (potential places where dirt could stick)
- smooth transitions
 - easy quick cleaning

3

Hot air oven

- hot air baking
- high capacity and variability
- all-stainless design
 - suitable for meat, fish, baked pasta, white meat, sweet pastries
 - long service life
 - easy to clean

4

Degree of protection of the control elements IPX4

- maintenance-free system
- resistance to splash water
- long life
 - savings on service interventions
 - greater job security for staff

5

All stainless steel design

- long life
- resistance of AISI 304 stainless steel material
- the material does not cut
 - savings on service interventions
 - easy cleaning and maintenance of equipment

6

Safety element – thermocouple

- safe service for staff
- there is no unnecessary gas leakage
- long life
 - savings on service interventions
 - easier and faster operation

7

Removable basin under the burners

- removable top plate without tools
 - easier cleaning
 - dishwasher safe
 - easier servicing

Technical data sheet



Technical parameters

Cooking range combined with electric convection oven GN 1/1 - 4x burner

Model

SAP Code

00002053

1. SAP Code:

00002053

2. Net Width [mm]:

658

3. Net Depth [mm]:

609

4. Net Height [mm]:

900

5. Net Weight [kg]:

65.00

6. Gross Width [mm]:

705

7. Gross depth [mm]:

725

8. Gross Height [mm]:

1120

9. Gross Weight [kg]:

72.00

10. Device type:

Combined unit

11. Construction type of device:

With substructure

12. Power electric [kW]:

3.130

13. Loading:

230 V / 1N - 50 Hz

14. Power gas [kW]:

18.000

15. Type of gas:

Natural gas, propane butane

16. Protection of controls:

IPX4

17. Material:

AISI 304 top plate, AISI 430 cladding

18. Indicators:

running and heating the oven

19. Worktop material:

AISI 304

20. Worktop Thickness [mm]:

0.80

21. Number of zones:

4

22. Power consumption of the zone 1 [kW]:

4,5

23. Power consumption of the zone 2 [kW]:

4,5

24. Power consumption of the zone 3 [kW]:

4,5

25. Power consumption of the zone 4 [kW]:

4,5

26. Number of power control stages:

6

27. Safety thermostat up to x ° C:

360

28. Adjustable feet:

Yes

Technical data sheet



Technical parameters

Cooking range combined with electric convection oven GN 1/1 - 4x burner

Model

SAP Code

00002053

29. Number of burners/hot plates:

4

30. Type of gas cooking zones:

Brass burners

31. Oven Type:

electric hot air

32. Type of internal part of the appliance 1 (eg oven):

Electric

33. Type of internal part of the appliance 2 (eg oven):

Hot air

34. Width of internal part [mm]:

548

35. Depth of internal part [mm]:

360

36. Height of internal part [mm]:

338

37. Maximum temperature of the inner chamber [°C]:

300

38. Minimum temperature of the inner chamber [°C]:

50

39. Number of internal parts:

4