

Technical data sheet

Product features



Fry-top griddle plate 116x51 gas combined on open cabinet

Model	SAP Code	00001042
--------------	-----------------	----------



- Top type: Combined
- Griddle dimensions [mm x mm]: 1160 x 510
- Griddle thickness [mm]: 14.00
- Worktop material: Stainless steel
- Container for liquid fat: Yes
- Independent heating zones: Separate control for each heating zone
- Maximum device temperature [°C]: 300
- Removable rim: Yes
- Ignition: Piezo+večný plamen

SAP Code	00001042	Power gas [kW]	21.000
Net Width [mm]	1200	Type of gas	Natural gas, propane butane
Net Depth [mm]	705	Griddle dimensions [mm x mm]	1160 x 510
Net Height [mm]	900	Top type	Combined
Net Weight [kg]	137.50	Worktop type	Molded - comfortable cleaning maintenance

Technical data sheet

Technical drawing



Fry-top griddle plate 116x51 gas combined on open cabinet

Model

SAP Code

00001042

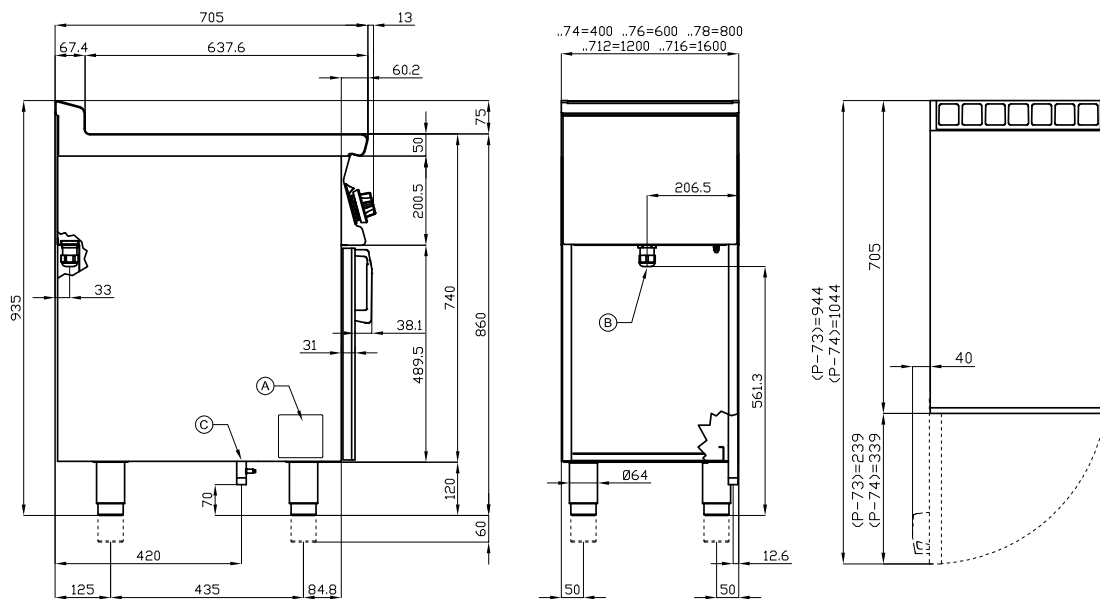

A	Data plate		C	Gas connection	ISO 7-1 1/2" M
---	------------	--	---	----------------	----------------

Technical data sheet

Product benefits



Fry-top griddle plate 116x51 gas combined on open cabinet

Model

SAP Code

00001042

1

Safety element – thermocouple

safe service for staff
there is no unnecessary gas leakage
long life

- savings on service interventions
- easier and faster operation

2

All-stainless design

long life
resistance of AISI 304 stainless steel material
the material does not cut

- savings on service interventions
- easy cleaning and maintenance of equipment

3

Degree of protection of the control elements IPX5

maintenance-free system
resistance to splash water
long life

- savings on service interventions
- easy cleaning and maintenance of equipment

4

Outlet for waste liquids

ensures that oil drips into the socket

- easy maintenance
- easy cleaning

5

High detachable hem

better hygienic conditions
preventing grease from splashing onto
ancillary equipment

- easy maintenance
- easy cleaning

6

Combined steel plate

good heat transfer and the surface does not get scratched
enables preparation on smooth or grooved plates

- time-saving in food preparation
- easy preparation of different types of dishes

7

Outlet for waste liquids

ensures that oil drips into the socket

- easy maintenance
- easy cleaning

8

Combined grilling area

straight and grooved grid

- the possibility of preparing several types of
gastronomic treatments at the same time
- separate control of each area

Technical data sheet

Technical parameters



Fry-top griddle plate 116x51 gas combined on open cabinet

Model

SAP Code

00001042

1. SAP Code:

00001042

2. Net Width [mm]:

1200

3. Net Depth [mm]:

705

4. Net Height [mm]:

900

5. Net Weight [kg]:

137.50

6. Gross Width [mm]:

1230

7. Gross depth [mm]:

770

8. Gross Height [mm]:

1110

9. Gross Weight [kg]:

154.00

10. Device type:

Gas unit

11. Construction type of device:

Stationary

12. Power gas [kW]:

21.000

13. Ignition:

Piezo+večný plamen

14. Type of gas:

Natural gas, propane butane

15. Protection of controls:

IPX5

16. Device color:

Stainless steel

17. Material:

Stainless steel

18. Indicators:

operation and warm-up

19. Worktop type:

Molded - comfortable cleaning maintenance

20. Worktop material:

Stainless steel

21. Worktop Thickness [mm]:

2.00

22. Standard equipment for device:

comes with a stainless steel scraper for cleaning pastries

23. Maximum device temperature [°C]:

300

24. Minimum device temperature [°C]:

50

25. Power control type:

knob control

26. Service accessibility:

Trough the frontal panel

27. Safety element:

safety thermostat

28. Safety thermostat:

Yes

Technical data sheet

Technical parameters



Fry-top griddle plate 116x51 gas combined on open cabinet

Model

SAP Code

00001042

29. Adjustable feet:

Yes

30. Additional information:

door not included - can be purchased

31. Griddle dimensions [mm x mm]:

1160 x 510

32. Griddle thickness [mm]:

14.00

33. Container for liquid fat:

Yes

34. Independent heating zones:

Separate control for each heating zone

35. Removable rim:

Yes

36. Uniform heating:

Yes

37. Top type:

Combinated