

Technical data sheet

Product features



Cooking range induction wok electric čínský 2x plate on open cabinet 400 V

Model	SAP Code	00002974
--------------	-----------------	----------



- Device type: Electric unit
- Power consumption of the zone 1 [kW]: 5
- Protection of controls: IPX5
- Material: Stainless steel

SAP Code	00002974	Power electric [kW]	5.000
Net Width [mm]	400	Loading	400 V / 3N - 50 Hz
Net Depth [mm]	705	Number of zones	1
Net Height [mm]	900	Power consumption of the zone 1 [kW]	5
Net Weight [kg]	33.00	Diameter of device [mm]	300

Technical data sheet

Technical drawing



Cooking range induction wok electric čínský 2x plate on open cabinet 400 V

Model

SAP Code

00002974

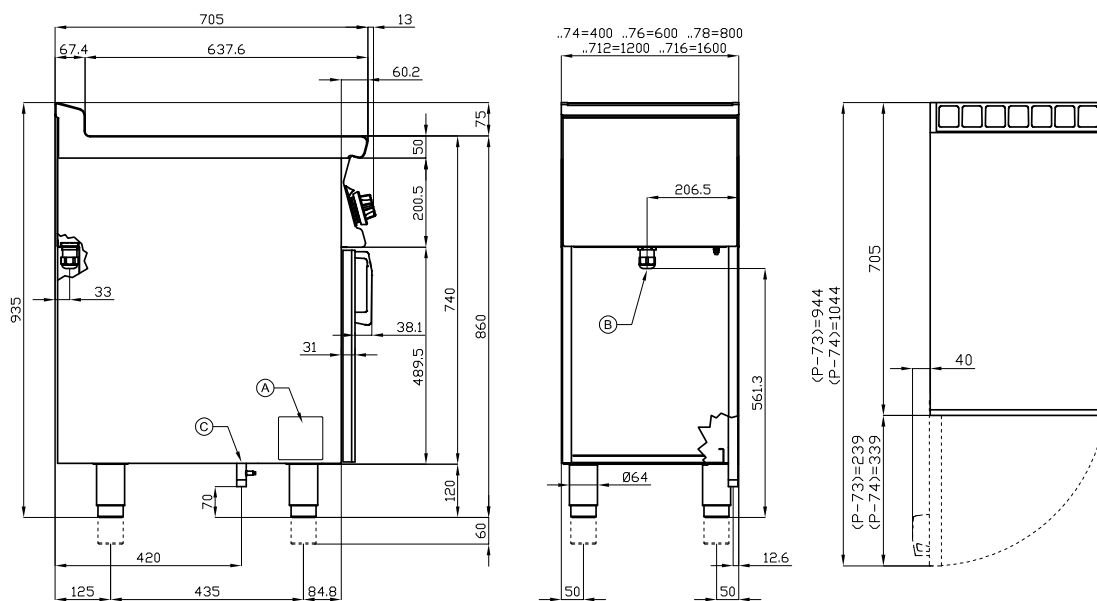

A	Data plate	B	Electrical connection
---	------------	---	-----------------------

Technical data sheet

Product benefits



Cooking range induction wok electric čínský 2x plate on open cabinet 400 V

Model

SAP Code

00002974

1

Induction wok surface

fastest heating of the cooking zone
precise heating only at the place where the container is placed

- time-saving for food preparation
- no reheating and long cooking times

2

Internal thermostatic plate protection

longer service life of the plates

- no overheating of the plates and no cracking

3

Degree of protection of the control elements IPX5

maintenance-free system
resistance to splash water
long life

- savings on service interventions
- easy cleaning and maintenance of equipment

4

All-stainless design

the material does not cut
wear resistance of the material
long life

- savings on service interventions
- easy cleaning and maintenance of equipment

5

Hygienic moldings of the top plate

absence of sharp corners and edges (potential places where dirt could stick)
smooth transitions

- easy quick cleaning

Technical data sheet

Technical parameters



Cooking range induction wok electric čínský 2x plate on open cabinet 400 V

Model

SAP Code

00002974

1. SAP Code:

00002974

2. Net Width [mm]:

400

3. Net Depth [mm]:

705

4. Net Height [mm]:

900

5. Net Weight [kg]:

33.00

6. Gross Width [mm]:

430

7. Gross depth [mm]:

770

8. Gross Height [mm]:

1110

9. Gross Weight [kg]:

38.00

10. Device type:

Electric unit

11. Construction type of device:

With substructure

12. Power electric [kW]:

5.000

13. Loading:

400 V / 3N - 50 Hz

14. Protection of controls:

IPX5

15. Material:

Stainless steel

16. Worktop material:

Glass ceramics

17. Worktop Thickness [mm]:

2.00

18. Number of zones:

1

19. Power consumption of the zone 1 [kW]:

5

20. Number of power control stages:

7

21. Service accessibility:

From the front by removing the front panel and waste fluid containers

22. Adjustable feet:

Yes

23. Additional information:

contact ceramic plate - transfers energy directly to the food
Wok version for use with a concave pan

24. Number of burners/hot plates:

1

25. Diameter of device [mm]:

300

26. Type of electric cooking zones:

Induction