

Technical data sheet

Product features



Fry-top griddle plate grooved

Model	SAP Code	00013640
--------------	-----------------	----------



- Top type: Grooved
- Griddle dimensions [mm x mm]: 760 x 680
- Griddle thickness [mm]: 14.00
- Worktop material: Stainless steel
- Container for liquid fat: Yes
- Maximum device temperature [°C]: 300

SAP Code	00013640	Power electric [kW]	15.000
Net Width [mm]	800	Loading	400 V / 3N - 50 Hz
Net Depth [mm]	900	Griddle dimensions [mm x mm]	760 x 680
Net Height [mm]	280	Top type	Grooved
Net Weight [kg]	93.00	Worktop type	Molded - comfortable cleaning maintenance

Technical data sheet

Technical drawing



Fry-top griddle plate grooved

Model

SAP Code

00013640

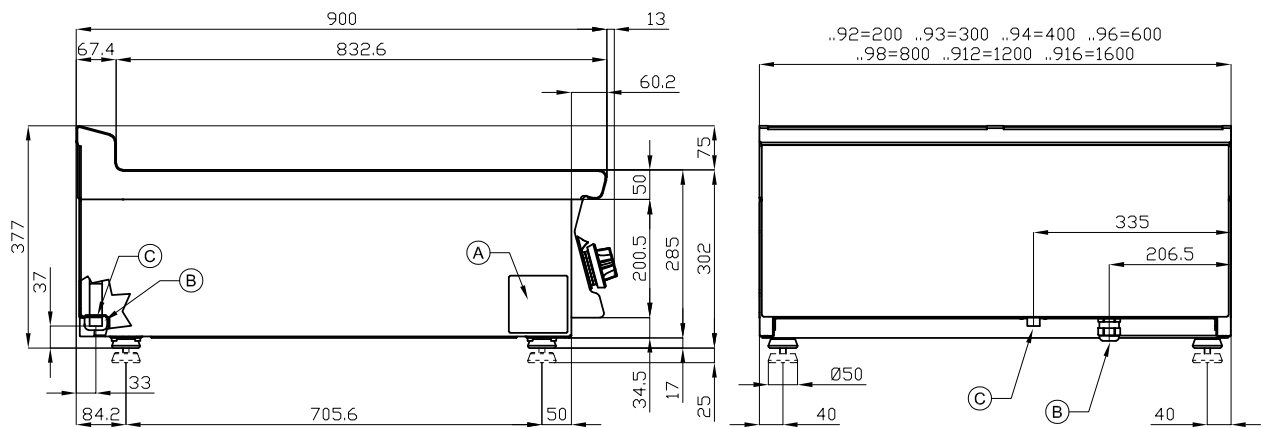

A	Data plate		B	Electrical connection	
---	------------	--	---	-----------------------	--

Technical data sheet

Technical parameters



Fry-top griddle plate grooved

Model

SAP Code

00013640

1. SAP Code:

00013640

2. Net Width [mm]:

800

3. Net Depth [mm]:

900

4. Net Height [mm]:

280

5. Net Weight [kg]:

93.00

6. Gross Width [mm]:

830

7. Gross depth [mm]:

970

8. Gross Height [mm]:

540

9. Gross Weight [kg]:

103.00

10. Device type:

Electric unit

11. Construction type of device:

Table top

12. Power electric [kW]:

15.000

13. Loading:

400 V / 3N - 50 Hz

14. Device color:

Stainless steel

15. Material:

AISI 304

16. Indicators:

operation and warm-up

17. Worktop type:

Molded - comfortable cleaning maintenance

18. Worktop material:

Stainless steel

19. Maximum device temperature [°C]:

300

20. Minimum device temperature [°C]:

50

21. Safety thermostat:

Yes

22. Adjustable feet:

Yes

23. Griddle dimensions [mm x mm]:

760 x 680

24. Griddle thickness [mm]:

14.00

25. Container for liquid fat:

Yes

26. Uniform heating:

Yes

27. Top type:

Grooved