

Technical data sheet

Product features



Cooking range solid top gas with static gas oven GN 2/1 - 1x burner

Model	SAP Code	00004684
--------------	-----------------	----------



- Device type: Gas unit
- Power consumption of the zone 1 [kW]: 12
- Ignition: Piezo+večný plamen
- Type of internal part of the appliance 1 (eg oven): Gas
- Type of internal part of the appliance 2 (eg oven): Static
- Protection of controls: IPX5
- Material: AISI 304

SAP Code	00004684	Power consumption of the zone 1 [kW]	12
Net Width [mm]	800	Type of internal part of the appliance 1 (eg oven)	Gas
Net Depth [mm]	900	Type of internal part of the appliance 2 (eg oven)	Static
Net Height [mm]	900	Width of internal part [mm]	680
Net Weight [kg]	178.00	Depth of internal part [mm]	730
Power gas [kW]	20.500	Height of internal part [mm]	340
Type of gas	Natural gas, propane butane	Solid top dimensions [mm x mm]	770 x 730
Number of zones	1		

Technical data sheet

Technical drawing



Cooking range solid top gas with static gas oven GN 2/1 - 1x burner

Model

SAP Code

00004684

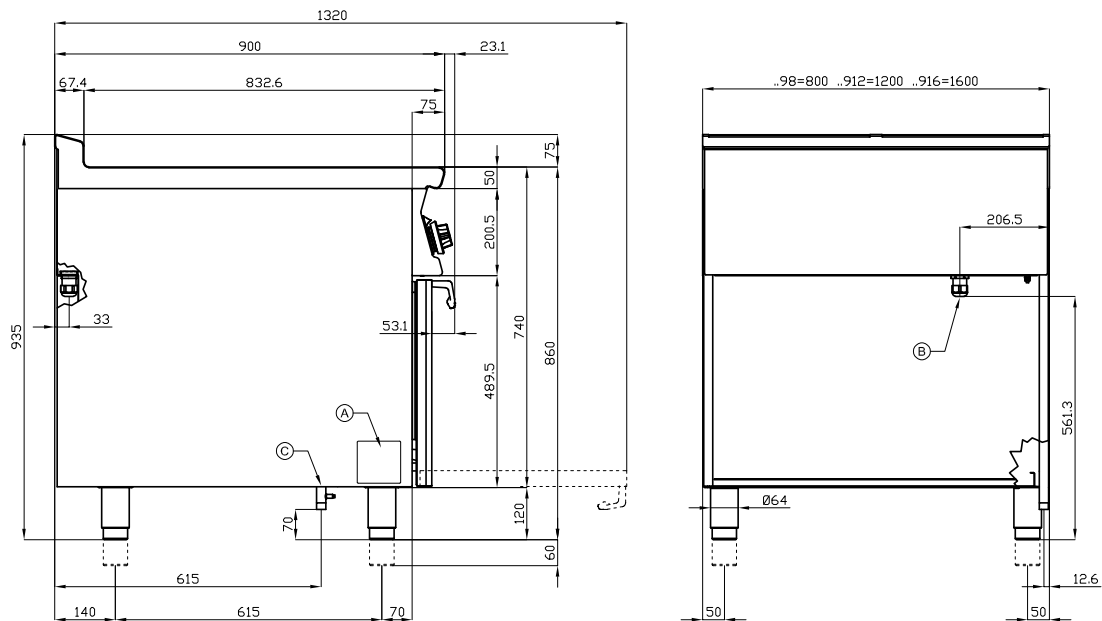

A	Data plate	C	Gas connection	ISO 7-1 3/4" M
---	------------	---	----------------	----------------

Technical data sheet

Product benefits



Cooking range solid top gas with static gas oven GN 2/1 - 1x burner

Model

SAP Code

00004684

1

Massive construction of burners

high performance and efficiency
brass burners removable
eternal flame
long life
demountable

- energy saving (perfect combustion)
- time saving for food preparation
- easy maintenance/cleaning

2

Hygienic moldings of the top plate

absence of sharp corners and edges (potential places where dirt could stick)
smooth transitions

- easy quick cleaning

3

Degree of protection of the control elements IPX5

maintenance-free system
resistance to splash water
long life

- savings on service interventions
- easy cleaning and maintenance of equipment

4

All-stainless design

the material does not cut
wear resistance of the material
long life

- savings on service interventions
- easy cleaning and maintenance of equipment

5

Safety element - thermocouple

safe operation for personnel
there is no overheating and damage to the thallus
long life

- savings on service interventions
- easier and faster operation

6

Piezoelectric ignition

instant flame ignition
there is no unnecessary gas leakage
long life

- savings on service interventions
- easier and faster operation

7

Massive thal

15mm material ensures even distribution of heat and heating of the product (heat several pots at the same time at the same temperature)
material resistance
long life

- time saving
- ease of operation
- savings on service interventions

8

Large electric oven with four positions for racks with static cooking

static baking
high capacity and variability
all-stainless design

- suitable for yeast dishes and desserts
- long service life
- easy to clean

Technical data sheet

Technical parameters



Cooking range solid top gas with static gas oven GN 2/1 - 1x burner

Model

SAP Code

00004684

1. SAP Code:

00004684

2. Net Width [mm]:

800

3. Net Depth [mm]:

900

4. Net Height [mm]:

900

5. Net Weight [kg]:

178.00

6. Gross Width [mm]:

830

7. Gross depth [mm]:

970

8. Gross Height [mm]:

1110

9. Gross Weight [kg]:

194.00

10. Device type:

Gas unit

11. Construction type of device:

With substructure

12. Power gas [kW]:

20.500

13. Ignition:

Piezo+večný plamen

14. Type of gas:

Natural gas, propane butane

15. Protection of controls:

IPX5

16. Device color:

Stainless steel

17. Material:

AISI 304

18. Worktop type:

Molded - comfortable cleaning maintenance

19. Worktop material:

AISI 304

20. Worktop Thickness [mm]:

2.00

21. Number of zones:

1

22. Power consumption of the zone 1 [kW]:

12

23. Number of power control stages:

6

24. Grid material:

Cast iron

25. Service accessibility:

From the front by removing the front panel and waste fluid containers

26. Safety thermocouple:

Yes

27. Safety thermostat up to x ° C:

360

28. Adjustable feet:

Yes

Technical data sheet

Technical parameters



Cooking range solid top gas with static gas oven GN 2/1 - 1x burner

Model

SAP Code

00004684

29. Number of burners/hot plates:

1

30. Type of gas cooking zones:

Thales

31. Oven Type:

gas static

32. Oven size:

GN 2/1

33. Oven material:

Stainless steel

34. Type of internal part of the appliance 1 (eg oven):

Gas

35. Type of internal part of the appliance 2 (eg oven):

Static

36. Width of internal part [mm]:

680

37. Depth of internal part [mm]:

730

38. Height of internal part [mm]:

340

39. Gasket:

Yes

40. Maximum temperature of the inner chamber [°C]:

300

41. Minimum temperature of the inner chamber [°C]:

150

42. Inner ignition:

Piezoelectric

43. Number of internal parts:

4

44. Solid top thickness [mm]:

15

45. Solid top dimensions [mm x mm]:

770 x 730

46. Solid top ignition:

Piezo + Eternal Flame