

Technical data sheet

Product features



Bain marie electric GN 1/1 + 2x 1/4 - 150 without cabinet

Model	SAP Code	00000091
--------------	-----------------	----------



- Drain type: On the front panel
- Drain: Yes
- Safety drain: Yes
- Material: AISI 304 top plate and cladding
- Protection of controls: IPX5
- Maximum device temperature [°C]: 30

SAP Code	00000091	Power electric [kW]	3.100
Net Width [mm]	600	Loading	230 V / 1N - 50 Hz
Net Depth [mm]	600	Number of GN / EN	3
Net Height [mm]	280	GN / EN size in device	GN 1/1 + 2x GN 1/4
Net Weight [kg]	21.00	GN device depth	150

Technical data sheet

Technical drawing



Bain marie electric GN 1/1 + 2x 1/4 - 150 without cabinet

Model

SAP Code

0000091

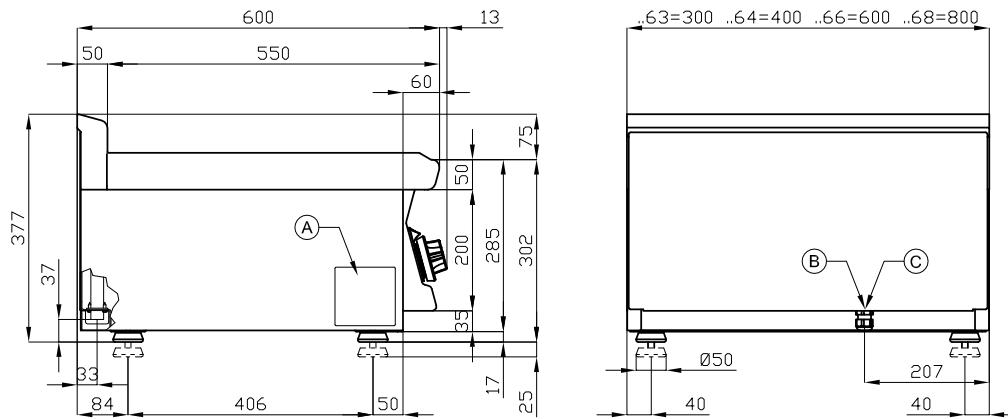

A	Data plate		B	Electrical connection	
---	------------	--	---	-----------------------	--

Technical data sheet

Product benefits



Bain marie electric GN 1/1 + 2x 1/4 - 150 without cabinet

Model

SAP Code

0000091

1

Deep-draft bathtubs

basins without sharp transitions, edges and corners

- easy maintenance
- perfect sanitation

2

All-stainless steel construction

harmless to health for contact with food
robustness

- perfect sanitation
- long service life

3

Drain valve with snap-on elbow for easy draining

safer placement of the drain valve

- valve location and use of an elbow and safety lock prevent unintentional contact and possible scalding

Technical data sheet

Technical parameters



Bain marie electric GN 1/1 + 2x 1/4 - 150 without cabinet

Model	SAP Code
	00000091

1. SAP Code:

00000091

2. Net Width [mm]:

600

3. Net Depth [mm]:

600

4. Net Height [mm]:

280

5. Net Weight [kg]:

21.00

6. Gross Width [mm]:

630

7. Gross depth [mm]:

690

8. Gross Height [mm]:

610

9. Gross Weight [kg]:

23.00

10. Device type:

Electric unit

11. Construction type of device:

Table top

12. Power electric [kW]:

3.100

13. Loading:

230 V / 1N - 50 Hz

14. Protection of controls:

IPX5

15. Device color:

Stainless steel

16. Material:

AISI 304 top plate and cladding

17. Indicators:

operation and warm-up

18. Drain valve diameter:

3/4"

19. Worktop type:

Molded - comfortable cleaning maintenance

20. Worktop material:

AISI 304

21. Worktop Thickness [mm]:

1.00

22. Device heating type:

Indirect

23. Standard equipment for device:

drain elbow

24. Basin dimensions [mm x mm x mm]:

GN 1/2-150 + 2x GN 1/4-150

25. Maximum device temperature [°C]:

30

26. Minimum device temperature [°C]:

90

27. Service accessibility:

Trough the frontal panel

28. Safety thermostat:

Yes

Technical data sheet

Technical parameters



Bain marie electric GN 1/1 + 2x 1/4 - 150 without cabinet

Model

SAP Code

00000091

29. Adjustable feet:

Yes

34. Drain:

Yes

30. Additional information:

Gastronutrients and lids not included

35. Safety drain:

Yes

31. Number of basins:

1

36. Number of GN / EN:

3

32. Basin material:

AISI 304 - High quality stainless steel

37. GN / EN size in device:

GN 1/1 + 2x GN 1/4

33. Drain type:

On the front panel

38. GN device depth:

150