

# Technical data sheet

## Product features



### Cooking range electric with static electric oven 3x GN 1/1 - 6x plate 400 V

<b>Model</b>	<b>SAP Code</b>	00000337
--------------	-----------------	----------



- Device type: Electric unit
- Power consumption of the zone 1 [kW]: 4
- Power consumption of the zone 2 [kW]: 4
- Power consumption of the zone 3 [kW]: 4
- Power consumption of the zone 4 [kW]: 4
- Power consumption of the zone 5 [kW]: 4
- Power consumption of the zone 6 [kW]: 4
- Type of internal part of the appliance 1 (eg oven): Electric
- Type of internal part of the appliance 2 (eg oven): Static
- Protection of controls: IPX5
- Material: AISI 304

<b>SAP Code</b>	00000337	<b>Power consumption of the zone 3 [kW]</b>	4
<b>Net Width [mm]</b>	1200	<b>Power consumption of the zone 4 [kW]</b>	4
<b>Net Depth [mm]</b>	900	<b>Power consumption of the zone 5 [kW]</b>	4
<b>Net Height [mm]</b>	900	<b>Power consumption of the zone 6 [kW]</b>	4
<b>Net Weight [kg]</b>	196.00	<b>Type of internal part of the appliance 1 (eg oven)</b>	Electric
<b>Power electric [kW]</b>	33.200	<b>Type of internal part of the appliance 2 (eg oven)</b>	Static
<b>Loading</b>	400 V / 3N - 50 Hz	<b>Width of internal part [mm]</b>	1085
<b>Number of zones</b>	6	<b>Depth of internal part [mm]</b>	730
<b>Power consumption of the zone 1 [kW]</b>	4	<b>Height of internal part [mm]</b>	340
<b>Power consumption of the zone 2 [kW]</b>	4	<b>Ceramic glass dimensions [mm x mm]</b>	750 x 750

# Technical data sheet

Technical drawing



Cooking range electric with static electric oven 3x GN 1/1 - 6x plate 400 V

Model

SAP Code

00000337

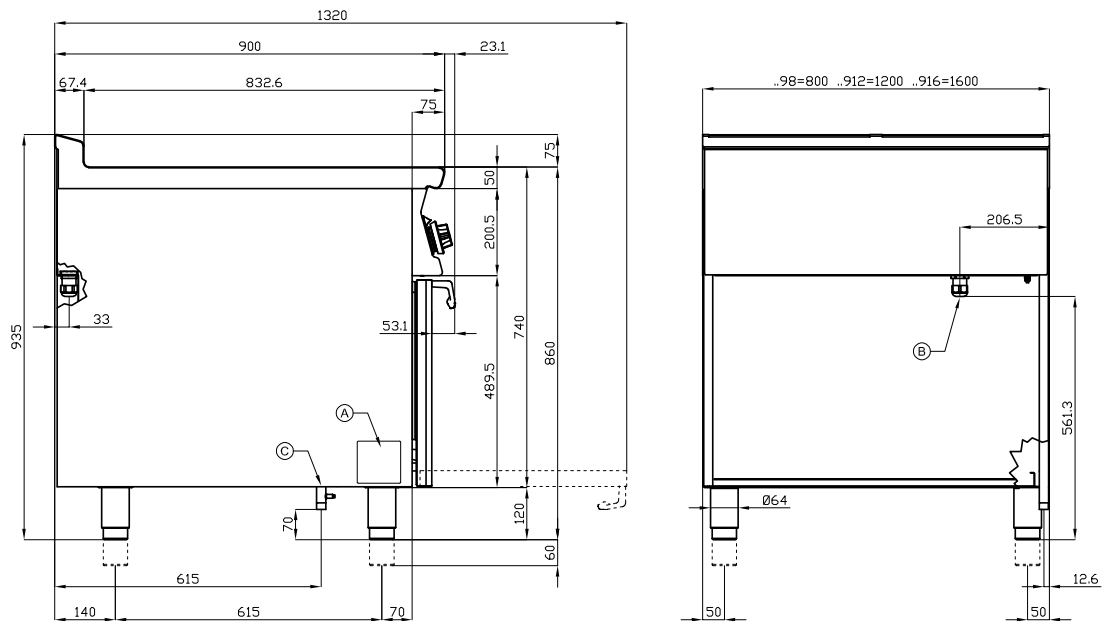

A	Data plate	B	Electrical connection
---	------------	---	-----------------------

# Technical data sheet

## Product benefits



### Cooking range electric with static electric oven 3x GN 1/1 - 6x plate 400 V

Model

SAP Code

00000337

1

#### Internal thermostatic plate protection

longer service life of the plates  
– no overheating of the plates and no cracking

2

#### Degree of protection of the control elements IPX5

maintenance-free system  
resistance to splash water  
long life  
– savings on service interventions  
– easy cleaning and maintenance of equipment

3

#### All-stainless design

the material does not cut  
wear resistance of the material  
long life  
– savings on service interventions  
– easy cleaning and maintenance of equipment

4

#### Hygienic moldings of the top plate

absence of sharp corners and edges (potential places where dirt could stick)  
smooth transitions  
– easy quick cleaning

5

#### Large oven with four rack positions with static cooking

static baking  
high capacity and variability  
all-stainless design  
– suitable for yeast dishes and desserts  
– long service life  
– easy to clean

# Technical data sheet

Technical parameters



Cooking range electric with static electric oven 3x GN 1/1 - 6x plate 400 V

Model

SAP Code

00000337

**1. SAP Code:**

00000337

**2. Net Width [mm]:**

1200

**3. Net Depth [mm]:**

900

**4. Net Height [mm]:**

900

**5. Net Weight [kg]:**

196.00

**6. Gross Width [mm]:**

1230

**7. Gross depth [mm]:**

970

**8. Gross Height [mm]:**

1110

**9. Gross Weight [kg]:**

218.00

**10. Device type:**

Electric unit

**11. Construction type of device:**

With substructure

**12. Power electric [kW]:**

33.200

**13. Loading:**

400 V / 3N - 50 Hz

**14. Protection of controls:**

IPX5

**15. Device color:**

Stainless steel

**16. Material:**

AISI 304

**17. Worktop type:**

Molded - comfortable cleaning maintenance

**18. Worktop material:**

AISI 304

**19. Worktop Thickness [mm]:**

2.00

**20. Device heating type:**

Static baking

**21. Number of zones:**

6

**22. Power consumption of the zone 1 [kW]:**

4

**23. Power consumption of the zone 2 [kW]:**

4

**24. Power consumption of the zone 3 [kW]:**

4

**25. Power consumption of the zone 4 [kW]:**

4

**26. Power consumption of the zone 5 [kW]:**

4

**27. Power consumption of the zone 6 [kW]:**

4

**28. Maximum device temperature [°C]:**

300

# Technical data sheet

Technical parameters



Cooking range electric with static electric oven 3x GN 1/1 - 6x plate 400 V

Model

SAP Code

00000337

**29. Minimum device temperature [°C]:**

50

**30. Number of power control stages:**

6

**31. Service accessibility:**

From the front by removing the front panel and waste fluid containers

**32. Safety thermostat:**

Yes

**33. Safety thermostat up to x °C:**

360

**34. Adjustable feet:**

Yes

**35. Number of burners/hot plates:**

6

**36. Type of electric cooking zones:**

Squared

**37. Oven Type:**

electrical static

**38. Oven size:**

GN 3x 1/1

**39. Oven material:**

Stainless steel

**40. Type of internal part of the appliance 1 (eg oven):**

Electric

**41. Type of internal part of the appliance 2 (eg oven):**

Static

**42. Width of internal part [mm]:**

1085

**43. Depth of internal part [mm]:**

730

**44. Height of internal part [mm]:**

340

**45. Gasket:**

Yes

**46. Maximum temperature of the inner chamber [°C]:**

300

**47. Minimum temperature of the inner chamber [°C]:**

50

**48. Number of internal parts:**

4

**49. Ceramic glass dimensions [mm x mm]:**

750 x 750