

# Technical data sheet

## Product features



### Electric fryer 18 l electronic 7" TouchScreen, filtration

<b>Model</b>	<b>SAP Code</b>	00014421
--------------	-----------------	----------



- Basin volume [l]: 18
- Drain type: Trough the cabinet
- Drain: Yes
- Maximum device temperature [°C]: 190
- Minimum device temperature [°C]: 50
- Material: AISI 304
- Number of baskets: 2
- Basket dimensions [mm x mm x mm]: 135x290x150

<b>SAP Code</b>	00014421	<b>Loading</b>	400 V / 3N - 50 Hz
<b>Net Width [mm]</b>	400	<b>Basin volume [l]</b>	18
<b>Net Depth [mm]</b>	705	<b>Number of basins</b>	1
<b>Net Height [mm]</b>	900	<b>Number of baskets</b>	2
<b>Net Weight [kg]</b>	65.00	<b>Basket dimensions [mm x mm x mm]</b>	135x290x150
<b>Power electric [kW]</b>	16.200	<b>Production of fries [kg/h]</b>	27

# Technical data sheet

Technical drawing



Electric fryer 18 l electronic 7" TouchSreen, filtration

Model

SAP Code

00014421

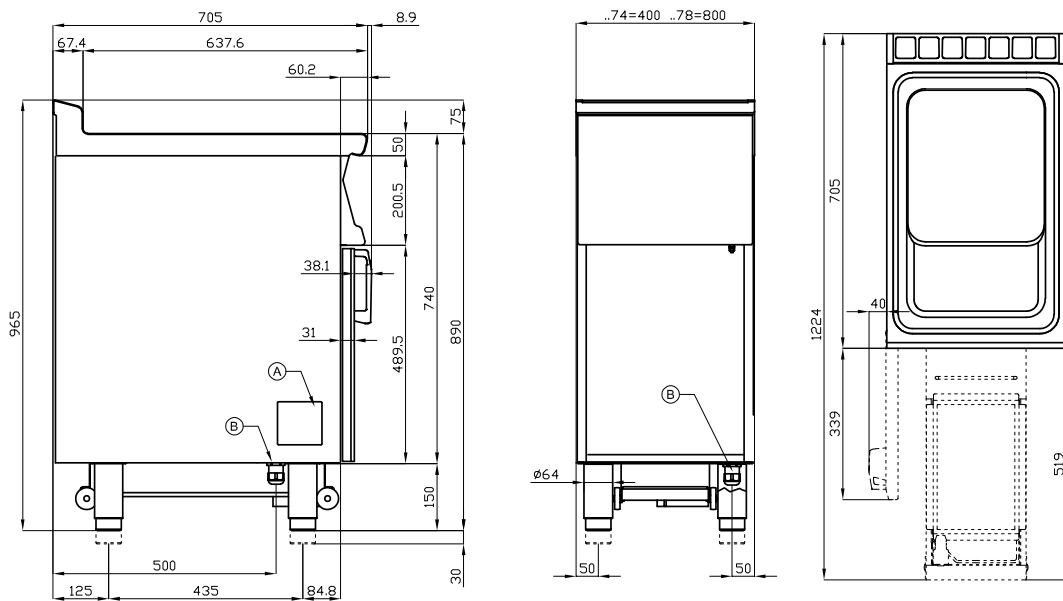

A Data plate		B Electrical connection	
--------------	--	-------------------------	--

# Technical data sheet

Technical parameters



## Electric fryer 18 l electronic 7" TouchScreen, filtration

**Model**

**SAP Code**

00014421

**1. SAP Code:**

00014421

**2. Article group:**

Fryers

**3. Net Width [mm]:**

400

**4. Net Depth [mm]:**

705

**5. Net Height [mm]:**

900

**6. Net Weight [kg]:**

65.00

**7. Gross Width [mm]:**

430

**8. Gross depth [mm]:**

770

**9. Gross Height [mm]:**

1110

**10. Gross Weight [kg]:**

73.00

**11. Device type:**

Electric unit

**12. Construction type of device:**

With substructure

**13. Power electric [kW]:**

16.200

**14. Loading:**

400 V / 3N - 50 Hz

**15. Protection of controls:**

IPX5

**16. Device color:**

Stainless steel

**17. Material:**

AISI 304

**18. Worktop type:**

Molded - comfortable cleaning maintenance

**19. Standard equipment for device:**

2 baskets 1/2  
strainer and tub lid  
oil collection container with wheels with 5 micron sieve  
(100 pcs of parts)  
1 TPA-7 side bar

**20. Basin volume [l]:**

18

**21. Basin dimensions [mm x mm x mm]:**

310x340x330

**22. Maximum device temperature [°C]:**

190

**23. Minimum device temperature [°C]:**

50

**24. Power control type:**

digital

**25. Safety element:**

oil presence and maximum level sensor

**26. Adjustable feet:**

Yes

# Technical data sheet

Technical parameters



## Electric fryer 18 l electronic 7" TouchScreen, filtration

Model	SAP Code	
		00014421

### 27. Additional information:

7 display  
Up to 100 programs can be stored in memory

### 31. Basket dimensions [mm x mm x mm]:

135x290x150

### 28. Heating element material:

AISI 304

### 32. Production of fries [kg/h]:

27

### 29. Number of baskets:

2

### 33. Drain type:

Trough the cabinet

### 30. Number of basins:

1

### 34. Drain:

Yes