

Technical data sheet



Product features

Electric fryer 0,74 kW/l, 11 l counter top drain tap 400 V

Model	SAP Code	00000896
--------------	-----------------	----------



- Basin volume [l]: 11
- Drain type: On the front panel
- Drain: Yes
- Maximum device temperature [°C]: 190
- Minimum device temperature [°C]: 50
- Material: Stainless steel
- Heating location: Inside the tank
- Ignition: Electric
- Number of baskets: 1

SAP Code	00000896	Power electric [kW]	8.100
Net Width [mm]	392	Loading	400 V / 3N - 50 Hz
Net Depth [mm]	440	Basin volume [l]	11
Net Height [mm]	381	Number of baskets	1
Net Weight [kg]	11.50		

Technical data sheet



Technical drawing

Electric fryer 0,74 kW/l, 11 l counter top drain tap 400 V

Model

SAP Code

00000896

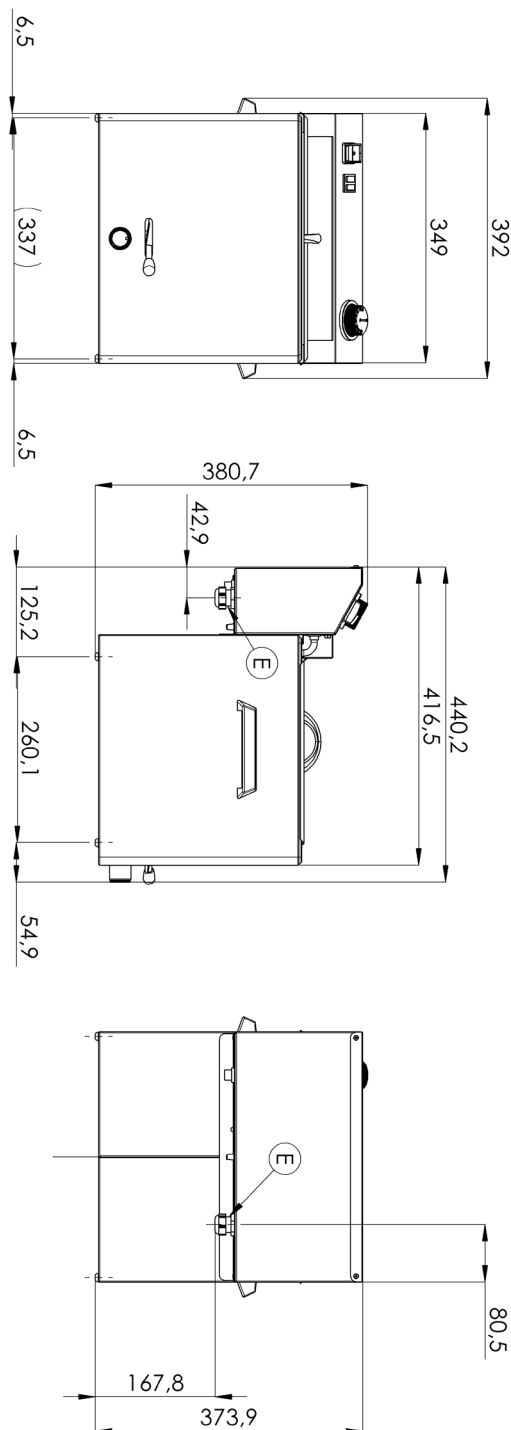

Electric fryer 0,74 kW/l, 11 l counter top drain tap 400 V

Model

SAP Code

00000896

1

All-stainless design

long life
resistance of AISI 304 stainless steel material
the material does not cut

- savings on service interventions
- easier and faster operation

2

Degree of protection of the control elements IPX4

maintenance-free system
resistance to splash water
long life

- savings on service interventions
- easy cleaning and maintenance of equipment

3

Effective cold zone

prevents food residues from burning
there is no change in the taste of the oil

- longer oil life
- easy access and maintenance

4

Removable heating element

longer lifetime
easy access

- fully removable electric box with heating element for convenient cleaning and servicing
- easy access even to corners and time saving

5

Removable container

stainless steel container with handles

- easier cleaning and handling
- dishwasher safe

6

Manipulation

easy portability

- flexibility in the kitchen, can be used for banquets

7

Prevention of spontaneous combustion

higher rear chimney

- safer heat dissipation and separation of oil and ventilation from the fryer

8

2 thermostats

safety and working thermostat

- traffic safety
- prevention of spontaneous combustion
- Prevention of oil flashover

Technical data sheet



Technical parameters

Electric fryer 0,74 kW/l, 11 l counter top drain tap 400 V

Model	SAP Code	00000896
--------------	-----------------	----------

1. SAP Code:

00000896

2. Article group:

Fryers

3. Net Width [mm]:

392

4. Net Depth [mm]:

440

5. Net Height [mm]:

381

6. Net Weight [kg]:

11.50

7. Gross Width [mm]:

515

8. Gross depth [mm]:

400

9. Gross Height [mm]:

440

10. Gross Weight [kg]:

13.00

11. Device type:

Electric unit

12. Construction type of device:

Table top

13. Power electric [kW]:

8.100

14. Loading:

400 V / 3N - 50 Hz

15. Ignition:

Electric

16. Protection of controls:

IPX4

17. Material:

Stainless steel

18. Indicators:

operation and warm-up

19. Worktop material:

AISI 304

20. Worktop Thickness [mm]:

0.80

21. Standard equipment for device:

lid, basket, drain plug

22. Basin volume [l]:

11

23. Maximum device temperature [°C]:

190

24. Minimum device temperature [°C]:

50

25. Safety thermostat up to x ° C:

235

26. Adjustable feet:

Yes

27. Heating element material:

AISI 304

28. Number of baskets:

1

Technical data sheet



Technical parameters

Electric fryer 0,74 kW/l, 11 l counter top drain tap 400 V

Model	SAP Code	00000896
--------------	-----------------	----------

29. Heating element construction:

Large surface area coiled heating element to extend its life and heat the oil bath evenly

31. Drain:

Yes

30. Drain type:

On the front panel

32. Heating location:

Inside the tank