

# Technical data sheet

## Product features



### Electric fryer 2 baskets 0,4 kW/l, 10+10 l without cabinet 230 V

<b>Model</b>	<b>SAP Code</b>	00000804
--------------	-----------------	----------



- Basin volume [l]: 10
- Drain type: On the front panel
- Drain: Yes
- Safety drain: Yes
- Maximum device temperature [°C]: 190
- Minimum device temperature [°C]: 50
- Material: AISI 304 top plate and cladding
- Heating location: Inside the tank
- Ignition: Electric
- Number of baskets: 2

<b>SAP Code</b>	00000804	<b>Power electric [kW]</b>	7.200
<b>Net Width [mm]</b>	600	<b>Loading</b>	230 V / 1N - 50 Hz
<b>Net Depth [mm]</b>	600	<b>Basin volume [l]</b>	10
<b>Net Height [mm]</b>	280	<b>Number of baskets</b>	2
<b>Net Weight [kg]</b>	30.00		

# Technical data sheet

Technical drawing



Electric fryer 2 baskets 0,4 kW/l, 10+10 l without cabinet 230 V

Model

SAP Code

00000804

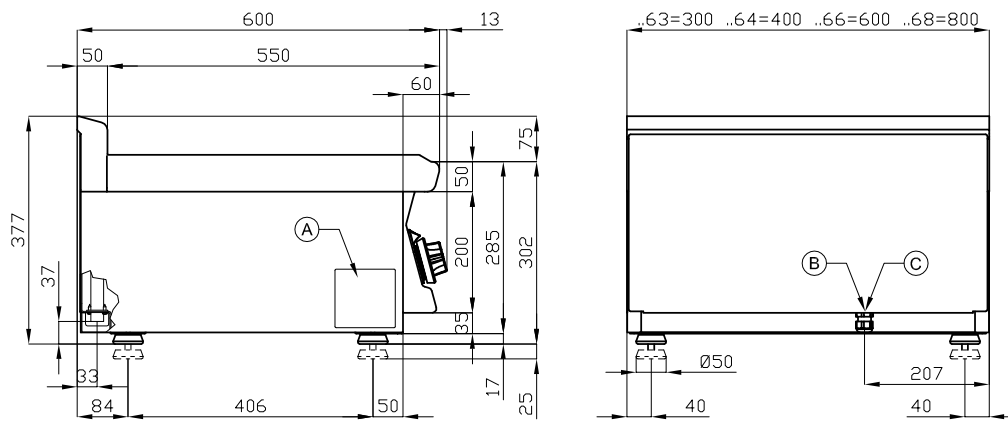

A	Data plate		B	Electrical connection	
---	------------	--	---	-----------------------	--

# Technical data sheet

## Product benefits



### Electric fryer 2 baskets 0,4 kW/l, 10+10 l without cabinet 230 V

Model

SAP Code

00000804

1

#### All-stainless steel bathtub

long life  
resistance of AISI 304 stainless steel material  
the material does not cut

- savings on service interventions
- easier and faster operation

2

#### Degree of protection of the control elements IPX4

maintenance-free system  
resistance to splash water  
long life

- savings on service interventions
- easy cleaning and maintenance of equipment

3

#### Drain valve "A" in the front part of the device with a safety lock against self-draining

outlet of the bath into the prepared container

- easy and safe handling

4

#### Cold zone

prevents food residues from burning  
there is no change in the taste of the oil

- longer oil life
- easy access and maintenance

5

#### Rotating heating element

longer lifetime  
easy access

- effective cleaning when the body is tipped out
- easy access even to corners and time saving

# Technical data sheet

Technical parameters



## Electric fryer 2 baskets 0,4 kW/l, 10+10 l without cabinet 230 V

**Model**

**SAP Code**

00000804

**1. SAP Code:**

00000804

**2. Net Width [mm]:**

600

**3. Net Depth [mm]:**

600

**4. Net Height [mm]:**

280

**5. Net Weight [kg]:**

30.00

**6. Gross Width [mm]:**

630

**7. Gross depth [mm]:**

690

**8. Gross Height [mm]:**

610

**9. Gross Weight [kg]:**

34.00

**10. Device type:**

Electric unit

**11. Construction type of device:**

Table top

**12. Power electric [kW]:**

7.200

**13. Loading:**

230 V / 1N - 50 Hz

**14. Ignition:**

Electric

**15. Protection of controls:**

IPX5

**16. Device color:**

Stainless steel

**17. Material:**

AISI 304 top plate and cladding

**18. Indicators:**

operation and warm-up

**19. Worktop material:**

Stainless steel

**20. Worktop Thickness [mm]:**

1.00

**21. Standard equipment for device:**

lid and basket

**22. Basin volume [l]:**

10

**23. Basin dimensions [mm x mm x mm]:**

220 x 350 x 230

**24. Maximum device temperature [°C]:**

190

**25. Minimum device temperature [°C]:**

50

**26. Service accessibility:**

Trough the frontal panel

**27. Safety thermostat:**

Yes

**28. Safety thermostat up to x °C:**

235

# Technical data sheet

Technical parameters



Electric fryer 2 baskets 0,4 kW/l, 10+10 l without cabinet 230 V

Model

SAP Code

0000804

**29. Adjustable feet:**

Yes

**30. Heating element material:**

AISI 304

**31. Number of baskets:**

2

**32. Basin material:**

AISI 304 - High quality stainless steel

**33. Drain type:**

On the front panel

**34. Drain:**

Yes

**35. Safety drain:**

Yes

**36. Heating location:**

Inside the tank