

Technical data sheet



Product features

Fry-top griddle plate 40x51 electric grooved without cabinet 400 V

Model	SAP Code	00110068
--------------	-----------------	----------



- Top type: Grooved
- Griddle dimensions [mm x mm]: 400 x 510
- Griddle thickness [mm]: 12.00
- Worktop material: Sandblasted steel
- Container for liquid fat: Yes
- Maximum device temperature [°C]: 300
- Surface finish: sandblasted surface without coating
- Removable rim: Yes

SAP Code	00110068	Power electric [kW]	4.500
Net Width [mm]	400	Loading	400 V / 3N - 50 Hz
Net Depth [mm]	700	Griddle dimensions [mm x mm]	400 x 510
Net Height [mm]	330	Top type	Grooved
Net Weight [kg]	36.00		

Technical data sheet



Technical drawing

Fry-top griddle plate 40x51 electric grooved without cabinet 400 V

Model	SAP Code	00110068
-------	----------	----------

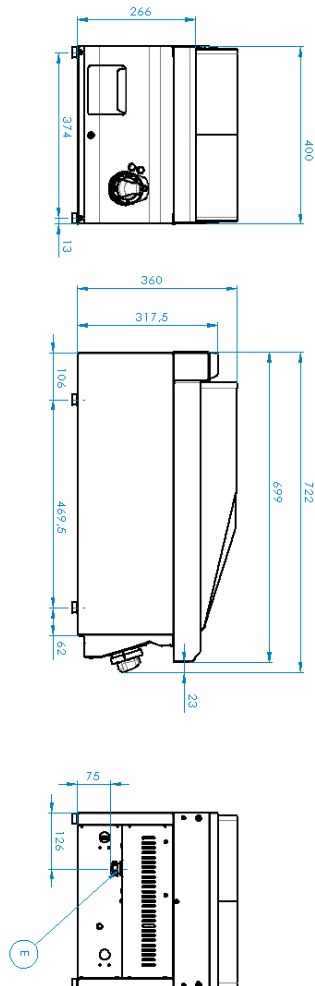

Technical data sheet



Product benefits

Fry-top griddle plate 40x51 electric grooved without cabinet 400 V

Model

SAP Code

00110068

1

All-stainless design

- long life
- corrosion resistance of the top plate material
 - savings on service interventions
 - easier and faster operation

2

Degree of protection of the control elements IPX4

- maintenance-free system
- resistance to splash water
- long life
 - savings on service interventions
 - easy cleaning and maintenance of equipment

3

Outlet for waste liquids

- ensures that oil drips into the socket
 - easy maintenance
 - easy cleaning

4

High detachable hem

- better hygienic conditions
- preventing grease from splashing onto ancillary equipment
 - easy maintenance
 - easy cleaning

5

Ribbed steel plate

- fast heat transfer and the surface will not be scratched
- a good warming of the meat with a groove
 - time-saving in food preparation
 - easy preparation of good-looking food

6

Cooking unit for use on a table or on a base

- variable use
- the possibility of placement in smaller spaces
 - easy handling
 - cost savings on substructure

Technical data sheet



Technical parameters

Fry-top griddle plate 40x51 electric grooved without cabinet 400 V

Model	SAP Code	00110068
--------------	-----------------	----------

1. SAP Code:

00110068

2. Net Width [mm]:

400

3. Net Depth [mm]:

700

4. Net Height [mm]:

330

5. Net Weight [kg]:

36.00

6. Gross Width [mm]:

440

7. Gross depth [mm]:

800

8. Gross Height [mm]:

390

9. Gross Weight [kg]:

42.00

10. Device type:

Electric unit

11. Construction type of device:

Table top

12. Power electric [kW]:

4.500

13. Loading:

400 V / 3N - 50 Hz

14. Protection of controls:

IPX4

15. Material:

AISI 304 top plate, AISI 430 cladding

16. Indicators:

operation and warm-up

17. Worktop material:

Sandblasted steel

18. Worktop Thickness [mm]:

1.20

19. Surface finish:

sandblasted surface without coating

20. Maximum device temperature [°C]:

300

21. Minimum device temperature [°C]:

50

22. Service accessibility:

Trough the frontal panel

23. Safety thermostat:

Yes

24. Adjustable feet:

Yes

25. Griddle dimensions [mm x mm]:

400 x 510

26. Griddle thickness [mm]:

12.00

27. Container for liquid fat:

Yes

28. Removable rim:

Yes

Technical data sheet



Technical parameters

Fry-top griddle plate 40x51 electric grooved without cabinet 400 V

Model	SAP Code	00110068
--------------	-----------------	----------

29. Top type:

Grooved