

Technical data sheet

Product features



Fry-top griddle plate combined chromed

Model	SAP Code	00013648
--------------	-----------------	----------



- Top type: Grooved
- Griddle dimensions [mm x mm]: 760 x 680
- Griddle thickness [mm]: 15.00
- Worktop material: Super chrom
- Container for liquid fat: Yes
- Ignition: Piezo+veÄŤnÄŤ plamen

SAP Code	00013648	Power gas [kW]	18.000
Net Width [mm]	800	Type of gas	Propane butane, natural gas
Net Depth [mm]	900	Griddle dimensions [mm x mm]	760 x 680
Net Height [mm]	280	Top type	Grooved
Net Weight [kg]	98.00	Worktop type	Molded - comfortable cleaning maintenance

Technical data sheet

Technical drawing



Fry-top griddle plate combined chromed

Model

SAP Code

00013648

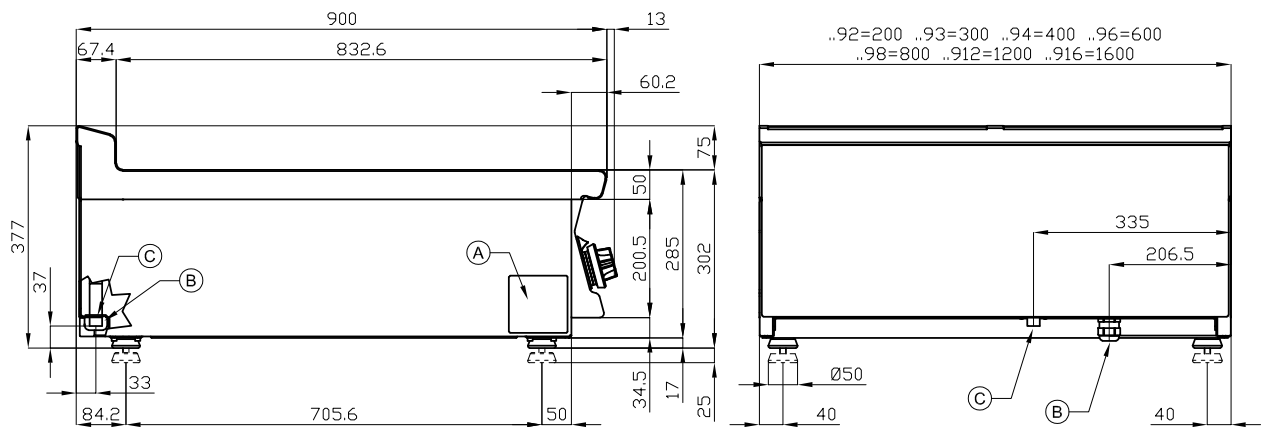

A	Data plate	C	Gas connection	ISO 7-1 1/2" M
---	------------	---	----------------	----------------

Technical data sheet

Technical parameters



Fry-top griddle plate combined chromed

Model

SAP Code

00013648

1. SAP Code:

00013648

2. Net Width [mm]:

800

3. Net Depth [mm]:

900

4. Net Height [mm]:

280

5. Net Weight [kg]:

98.00

6. Gross Width [mm]:

830

7. Gross depth [mm]:

970

8. Gross Height [mm]:

540

9. Gross Weight [kg]:

108.00

10. Device type:

Gas unit

11. Construction type of device:

Table top

12. Power gas [kW]:

18.000

13. Ignition:

Piezo+veřn plamen

14. Type of gas:

Propane butane, natural gas

15. Protection of controls:

IPX5

16. Device color:

Stainless steel

17. Material:

AISI 304

18. Indicators:

operation and warm-up

19. Worktop type:

Molded - comfortable cleaning maintenance

20. Worktop material:

Super chrom

21. Safety thermostat:

Yes

22. Adjustable feet:

Yes

23. Griddle dimensions [mm x mm]:

760 x 680

24. Griddle thickness [mm]:

15.00

25. Container for liquid fat:

Yes

26. Uniform heating:

Yes

27. Top type:

Grooved