

# Technical data sheet



## Product features

<b>Model</b>	<b>SAP Code</b>	00110057
FTH 70/04 G	<b>A group of articles - web</b>	Grills and grill plates



- Top type: Smooth
- Griddle dimensions [mm x mm]: 396 x 510
- Griddle thickness [mm]: 12.00
- Worktop material: Sandblasted steel
- Container for liquid fat: Yes
- Maximum device temperature [°C]: 300
- Surface finish: sandblasted surface without coating
- Removable rim: Yes
- Ignition: Piezo + večný plamen

<b>SAP Code</b>	00110057	<b>Power gas [kW]</b>	7.000
<b>Net Width [mm]</b>	400	<b>Type of gas</b>	Natural gas, propane butane
<b>Net Depth [mm]</b>	700	<b>Griddle dimensions [mm x mm]</b>	396 x 510
<b>Net Height [mm]</b>	330	<b>Top type</b>	Smooth
<b>Net Weight [kg]</b>	38.00	<b>Worktop type</b>	Molded - comfortable cleaning maintenance

# Technical data sheet



Technical drawing

<b>Model</b>	<b>SAP Code</b>	00110057
FTH 70/04 G	<b>A group of articles - web</b>	Grills and grill plates

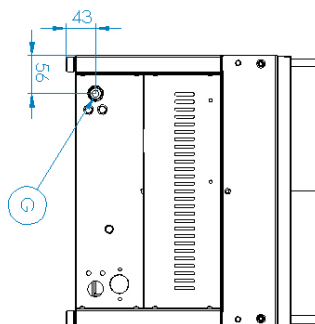
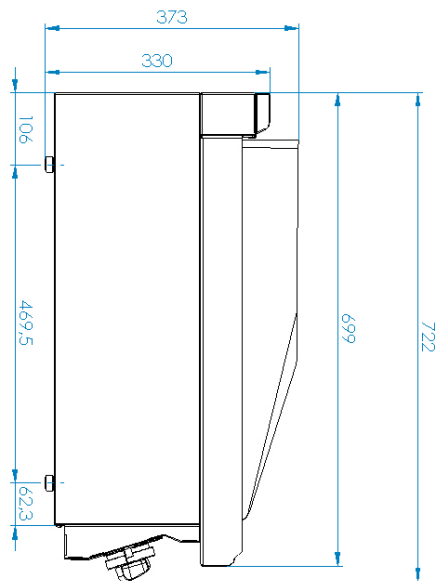
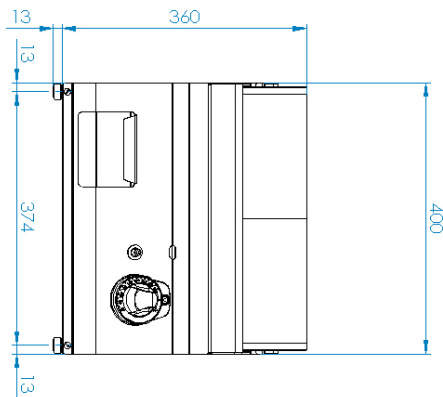

# Technical data sheet



## Product benefits

<b>Model</b>	<b>SAP Code</b>	00110057
FTH 70/04 G	<b>A group of articles - web</b>	Grills and grill plates

- 1 Safety element – thermocouple**  
safe service for staff  
there is no unnecessary gas leakage  
long life
  - savings on service interventions
  - easier and faster operation
- 2 All-stainless design**  
long life  
corrosion resistance of the top plate material
  - savings on service interventions
  - higher corrosion resistance
- 3 Degree of protection of the control elements IPX4**  
maintenance-free system  
resistance to splash water  
long life
  - savings on service interventions
  - easy cleaning and maintenance of equipment
- 4 Outlet for waste liquids**  
ensures that oil drips into the socket
  - easy maintenance
  - easy cleaning
- 5 High detachable hem**  
better hygienic conditions  
preventing grease from splashing onto ancillary equipment
  - easy maintenance
  - easy cleaning
- 6 Smooth steel plate**  
good heat transfer  
uniform heating
  - time-saving for food preparation
  - no reheating and long cooking times
- 7 Cooking unit for use on a table or on a base**  
variable use  
the possibility of placement in smaller spaces
  - easy handling
  - cost savings on substructure

# Technical data sheet



## Technical parameters

<b>Model</b>	<b>SAP Code</b>	00110057
<b>FTH 70/04 G</b>	<b>A group of articles - web</b>	Grills and grill plates

**1. SAP Code:**

00110057

**2. Article group:**

RF-Line 700

**3. Net Width [mm]:**

400

**4. Net Depth [mm]:**

700

**5. Net Height [mm]:**

330

**6. Net Weight [kg]:**

38.00

**7. Gross Width [mm]:**

440

**8. Gross depth [mm]:**

800

**9. Gross Height [mm]:**

390

**10. Gross Weight [kg]:**

44.00

**11. Device type:**

Gas unit

**12. Construction type of device:**

Table top

**13. Power gas [kW]:**

7.000

**14. Ignition:**

Piezo + večný plamen

**15. Type of gas:**

Natural gas, propane butane

**16. Protection of controls:**

IPX4

**17. Material:**

AISI 304 top plate, AISI 430 cladding

**18. Worktop type:**

Molded - comfortable cleaning maintenance

**19. Worktop material:**

Sandblasted steel

**20. Worktop Thickness [mm]:**

1.20

**21. Surface finish:**

sandblasted surface without coating

**22. Maximum device temperature [°C]:**

300

**23. Minimum device temperature [°C]:**

50

**24. Service accessibility:**

Trough the frontal panel

**25. Safety thermocouple:**

Yes

**26. Safety thermostat:**

Yes

**27. Adjustable feet:**

Yes

**28. Griddle dimensions [mm x mm]:**

396 x 510

**29. Griddle thickness [mm]:**

12.00

**30. Container for liquid fat:**

Yes

**31. Removable rim:**

Yes

**32. Top type:**

Smooth