

Technical data sheet

Product features



Fry-top griddle plate grooved chromed

Model

SAP Code

00013633



- Top type: Grooved
- Griddle dimensions [mm x mm]: 360 x 680
- Griddle thickness [mm]: 14.00
- Worktop material: Super chrom
- Container for liquid fat: Yes
- Maximum device temperature [°C]: 300

SAP Code	00013633	Power electric [kW]	7.500
Net Width [mm]	400	Loading	400 V / 3N - 50 Hz
Net Depth [mm]	900	Griddle dimensions [mm x mm]	360 x 680
Net Height [mm]	280	Top type	Grooved
Net Weight [kg]	59.00	Worktop type	Molded - comfortable cleaning maintenance

Technical data sheet

Technical drawing



Fry-top griddle plate grooved chromed

Model

SAP Code

00013633

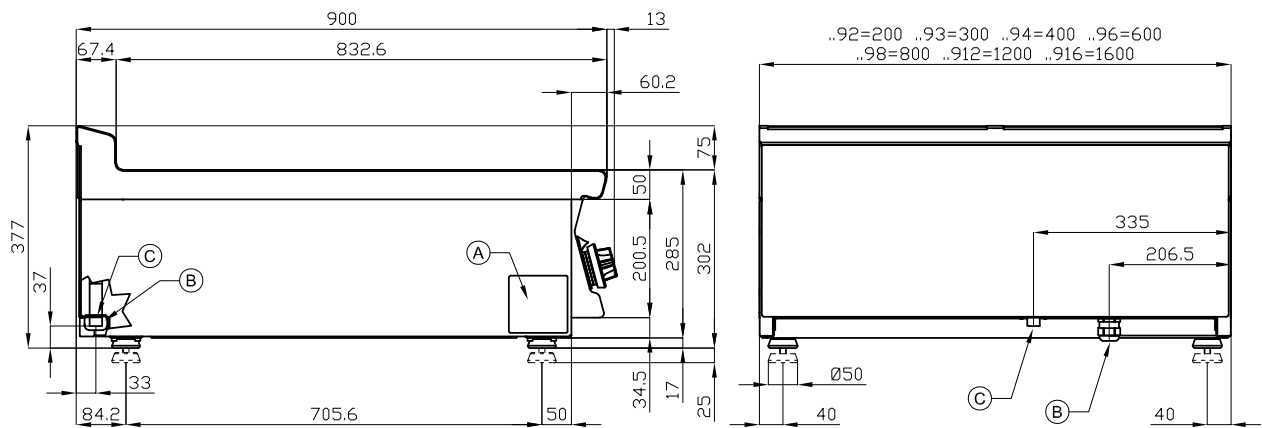

A	Data plate		B	Electrical connection	
---	------------	--	---	-----------------------	--

Technical data sheet

Technical parameters



Fry-top griddle plate grooved chromed

Model

SAP Code

00013633

1. SAP Code:

00013633

2. Net Width [mm]:

400

3. Net Depth [mm]:

900

4. Net Height [mm]:

280

5. Net Weight [kg]:

59.00

6. Gross Width [mm]:

430

7. Gross depth [mm]:

970

8. Gross Height [mm]:

540

9. Gross Weight [kg]:

69.00

10. Device type:

Electric unit

11. Construction type of device:

Table top

12. Power electric [kW]:

7.500

13. Loading:

400 V / 3N - 50 Hz

14. Protection of controls:

IPX5

15. Device color:

Stainless steel

16. Material:

AISI 304

17. Indicators:

operation and warm-up

18. Worktop type:

Molded - comfortable cleaning maintenance

19. Worktop material:

Super chrom

20. Maximum device temperature [°C]:

300

21. Minimum device temperature [°C]:

50

22. Safety thermostat:

Yes

23. Adjustable feet:

Yes

24. Griddle dimensions [mm x mm]:

360 x 680

25. Griddle thickness [mm]:

14.00

26. Container for liquid fat:

Yes

27. Uniform heating:

Yes

28. Top type:

Grooved