

Technical data sheet



Product features

Cooking range electric 6x plates

Model	SAP Code	00014647
--------------	-----------------	----------



- Device type: Electric unit
- Material: AISI 304

SAP Code	00014647	Net Weight [kg]	121.00
Net Width [mm]	1200	Power electric [kW]	21.000
Net Depth [mm]	900	Loading	400 V / 3N - 50 Hz
Net Height [mm]	900		

Technical data sheet



Technical drawing

Cooking range electric 6x plates

Model

SAP Code

00014647

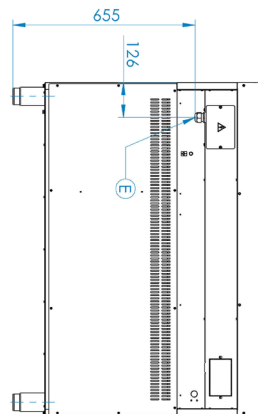
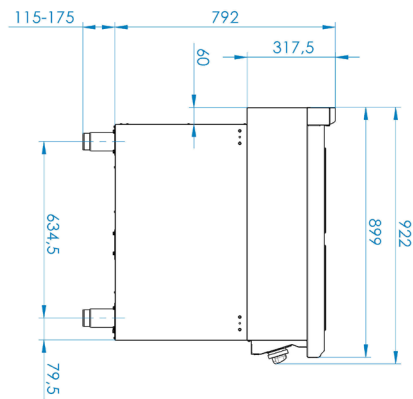
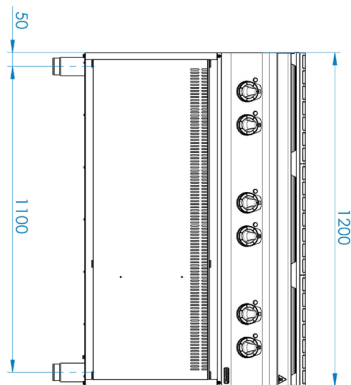

Technical data sheet



Technical parameters

Cooking range electric 6x plates

Model

SAP Code

00014647

1. SAP Code:

00014647

2. Article group:

RF-Line 900

3. Net Width [mm]:

1200

4. Net Depth [mm]:

900

5. Net Height [mm]:

900

6. Net Weight [kg]:

121.00

7. Gross Width [mm]:

1260

8. Gross depth [mm]:

990

9. Gross Height [mm]:

1180

10. Gross Weight [kg]:

140.00

11. Device type:

Electric unit

12. Power electric [kW]:

21.000

13. Loading:

400 V / 3N - 50 Hz

14. Material:

AISI 304

15. Worktop Thickness [mm]:

1.50

16. Number of power control stages:

7

17. Number of burners/hot plates:

6

18. Type of electric cooking zones:

Oval