

Technical data sheet

Product features



Cooking range electric with static electric oven GN 2/1 - 6x plate 400 V

Model	SAP Code	00005930
--------------	-----------------	----------



- Device type: Electric unit
- Power consumption of the zone 1 [kW]: 3,5
- Power consumption of the zone 2 [kW]: 3,5
- Power consumption of the zone 3 [kW]: 3,5
- Power consumption of the zone 4 [kW]: 3,5
- Power consumption of the zone 5 [kW]: 3,5
- Power consumption of the zone 6 [kW]: 3,5
- Type of internal part of the appliance 1 (eg oven): Electric
- Type of internal part of the appliance 2 (eg oven): Static
- Protection of controls: IPX5
- Material: AISI 304

SAP Code	00005930	Power consumption of the zone 3 [kW]	3,5
Net Width [mm]	1200	Power consumption of the zone 4 [kW]	3,5
Net Depth [mm]	900	Power consumption of the zone 5 [kW]	3,5
Net Height [mm]	900	Power consumption of the zone 6 [kW]	3,5
Net Weight [kg]	178.00	Type of internal part of the appliance 1 (eg oven)	Electric
Power electric [kW]	27.700	Type of internal part of the appliance 2 (eg oven)	Static
Loading	400 V / 3N - 50 Hz	Width of internal part [mm]	680
Number of zones	6	Depth of internal part [mm]	730
Power consumption of the zone 1 [kW]	3,5	Height of internal part [mm]	340
Power consumption of the zone 2 [kW]	3,5		

Technical data sheet

Technical drawing



Cooking range electric with static electric oven GN 2/1 - 6x plate 400 V

Model

SAP Code

00005930

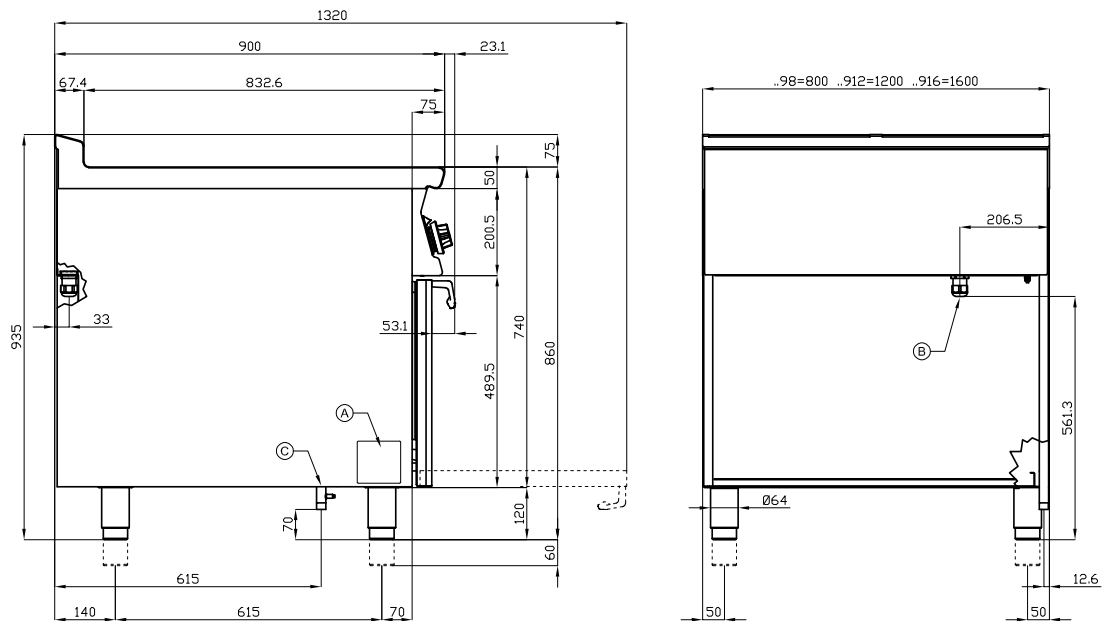

A	Data plate		B	Electrical connection	
---	------------	--	---	-----------------------	--

Technical data sheet

Product benefits



Cooking range electric with static electric oven GN 2/1 - 6x plate 400 V

Model	SAP Code	00005930
--------------	-----------------	----------

1

Round plates

- quick warm-up
efficient cooking on a round surface with easy
adhesion to dishes
- time-saving in food preparation
 - easy to use thanks to the large surface area of the
cooking plates

2

Internal thermostatic plate protection

- longer service life of the plates
- no overheating of the plates and no cracking

3

Degree of protection of the control elements IPX5

- maintenance-free system
resistance to splash water
long life
- savings on service interventions
 - easy cleaning and maintenance of equipment

4

All-stainless design

- the material does not cut
wear resistance of the material
long life
- savings on service interventions
 - easy cleaning and maintenance of equipment

5

Hygienic moldings of the top plate

- absence of sharp corners and edges (potential places
where dirt could stick)
smooth transitions
- easy quick cleaning

6

Large electric oven with four positions for racks with static cooking

- possibility of baking
high capacity and variability
all-stainless design
- suitable for yeast dishes and desserts
 - long service life
 - easy to clean

Technical data sheet

Technical parameters



Cooking range electric with static electric oven GN 2/1 - 6x plate 400 V

Model

SAP Code

00005930

1. SAP Code:

00005930

2. Net Width [mm]:

1200

3. Net Depth [mm]:

900

4. Net Height [mm]:

900

5. Net Weight [kg]:

178.00

6. Gross Width [mm]:

1230

7. Gross depth [mm]:

970

8. Gross Height [mm]:

1110

9. Gross Weight [kg]:

200.00

10. Device type:

Electric unit

11. Construction type of device:

With substructure

12. Power electric [kW]:

27.700

13. Loading:

400 V / 3N - 50 Hz

14. Protection of controls:

IPX5

15. Device color:

Stainless steel

16. Material:

AISI 304

17. Worktop type:

Molded - comfortable cleaning maintenance

18. Worktop material:

AISI 304

19. Worktop Thickness [mm]:

2.00

20. Number of zones:

6

21. Power consumption of the zone 1 [kW]:

3,5

22. Power consumption of the zone 2 [kW]:

3,5

23. Power consumption of the zone 3 [kW]:

3,5

24. Power consumption of the zone 4 [kW]:

3,5

25. Power consumption of the zone 5 [kW]:

3,5

26. Power consumption of the zone 6 [kW]:

3,5

27. Maximum device temperature [°C]:

300

28. Minimum device temperature [°C]:

50

Technical data sheet

Technical parameters



Cooking range electric with static electric oven GN 2/1 - 6x plate 400 V

Model

SAP Code

00005930

29. Number of power control stages:

6

30. Service accessibility:

From the front by removing the front panel and waste fluid containers

31. Safety thermostat:

Yes

32. Safety thermostat up to x ° C:

360

33. Adjustable feet:

Yes

34. Number of burners/hot plates:

6

35. Type of electric cooking zones:

Oval

36. Oven Type:

electrical static

37. Oven size:

GN 2/1

38. Oven material:

Stainless steel

39. Type of internal part of the appliance 1 (eg oven):

Electric

40. Type of internal part of the appliance 2 (eg oven):

Static

41. Width of internal part [mm]:

680

42. Depth of internal part [mm]:

730

43. Height of internal part [mm]:

340

44. Gasket:

Yes

45. Maximum temperature of the inner chamber [°C]:

300

46. Minimum temperature of the inner chamber [°C]:

50

47. Number of internal parts:

4