

# Technical data sheet

## Product features



### Bain marie trolley electric GN 2-1/1 controllers on shorter side with rack

<b>Model</b>	<b>SAP Code</b>	00000080
--------------	-----------------	----------



- Drain: Yes
- Material: AISI 304 top plate, AISI 430 cladding
- Protection of controls: IPX4
- Maximum device temperature [°C]: 90

<b>SAP Code</b>	00000080	<b>Power electric [kW]</b>	1.400
<b>Net Width [mm]</b>	598	<b>Loading</b>	230 V / 1N - 50 Hz
<b>Net Depth [mm]</b>	874	<b>Number of GN / EN</b>	2
<b>Net Height [mm]</b>	905	<b>GN / EN size in device</b>	GN 1/1
<b>Net Weight [kg]</b>	39.00	<b>GN device depth</b>	200

# Technical data sheet

Technical drawing



Bain marie trolley electric GN 2-1/1 controllers on shorter side with rack

<b>Model</b>	<b>SAP Code</b>	0000080
--------------	-----------------	---------

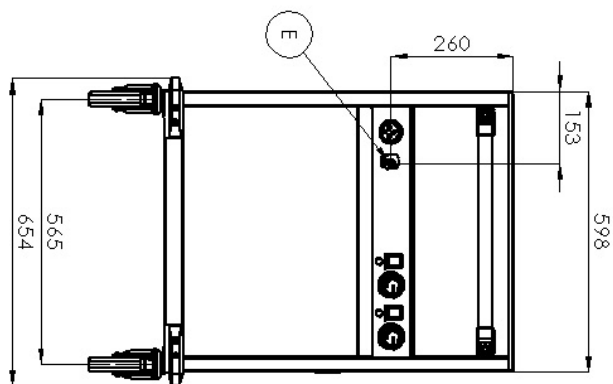
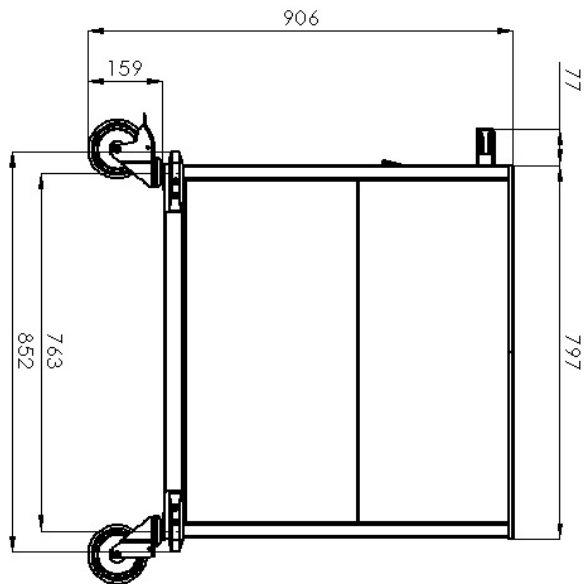

# Technical data sheet

## Product benefits



### Bain marie trolley electric GN 2-1/1 controllers on shorter side with rack

<b>Model</b>	<b>SAP Code</b>	0000080
--------------	-----------------	---------

- 1 Shelf**  
greater strength
  - more stability
  - storage space
- 2 Braked wheels**  
easy to control
  - more comfort for the operator
  - safety
  - stability
- 3 Deep-draft bathtubs**  
basins without sharp transitions, edges and corners
  - easy maintenance
  - perfect sanitation
- 4 Controlling each bath separately**  
variability of use
  - possibility to keep different foods at different temperatures
- 5 All-stainless steel construction**  
variability of use
  - perfect sanitation
  - long service life
- 6 Drain valve under the bathtub**  
safer placement of the drain valve
  - valve positioning prevents unintentional contact and possible scalding
- 7 Handrail**  
handle made of robust stainless steel tube  
possibility of placement on the shorter or longer side
  - easy handling of the dispensing tub

# Technical data sheet

Technical parameters



## Bain marie trolley electric GN 2-1/1 controllers on shorter side with rack

Model	SAP Code	00000080
-------	----------	----------

**1. SAP Code:**

00000080

**2. Article group:**

Bain Maries

**3. Net Width [mm]:**

598

**4. Net Depth [mm]:**

874

**5. Net Height [mm]:**

905

**6. Net Weight [kg]:**

39.00

**7. Gross Width [mm]:**

750

**8. Gross depth [mm]:**

910

**9. Gross Height [mm]:**

1010

**10. Gross Weight [kg]:**

40.00

**11. Device type:**

Electric unit

**12. Construction type of device:**

On wheels

**13. Power electric [kW]:**

1.400

**14. Loading:**

230 V / 1N - 50 Hz

**15. Protection of controls:**

IPX4

**16. Device color:**

Stainless steel

**17. Material:**

AISI 304 top plate, AISI 430 cladding

**18. Maximum device temperature [°C]:**

90

**19. Minimum device temperature [°C]:**

30

**20. Adjustable feet:**

No

**21. Drain:**

Yes

**22. Number of GN / EN:**

2

**23. GN / EN size in device:**

GN 1/1

**24. GN device depth:**

200