

Technical data sheet

Product features



Fry-top griddle plate 80x45 gas chromed grooved without cabinet

Model	SAP Code	00001136
--------------	-----------------	----------



- Top type: Grooved
- Griddle dimensions [mm x mm]: 795 x 450
- Griddle thickness [mm]: 14.00
- Worktop material: Super chrom
- Ignition: Piezo + večný plamen

SAP Code	00001136	Power gas [kW]	12.000
Net Width [mm]	800	Type of gas	Natural gas, propane butane
Net Depth [mm]	600	Griddle dimensions [mm x mm]	795 x 450
Net Height [mm]	280	Top type	Grooved
Net Weight [kg]	73.00		

Technical data sheet

Technical drawing



Fry-top griddle plate 80x45 gas chromed grooved without cabinet

Model

SAP Code

00001136

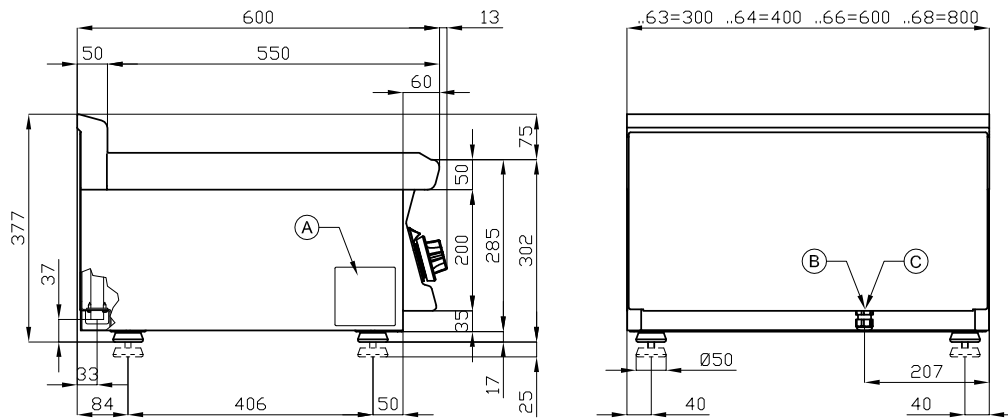

A	Data plate		C	Gas connection	ISO 7-1 1/2" M
---	------------	--	---	----------------	----------------

Technical data sheet

Product benefits



Fry-top griddle plate 80x45 gas chromed grooved without cabinet

Model

SAP Code

00001136

1

Safety element – thermocouple

safe service for staff
there is no unnecessary gas leakage
long life

- savings on service interventions
- easier and faster operation

2

All-stainless design

long life
resistance of AISI 304 stainless steel material
the material does not cut

- savings on service interventions
- easy cleaning and maintenance of equipment

3

Degree of protection of the control elements IPX5

maintenance-free system
resistance to splash water
long life

- savings on service interventions
- easy cleaning and maintenance of equipment

4

Outlet for waste liquids

ensures that oil drips into the socket

- easy maintenance
- easy cleaning

5

High detachable hem

better hygienic conditions
preventing grease from splashing onto ancillary equipment

- easy maintenance
- easy cleaning

6

Grooved plate made of chrome-plated steel

the product bakes less and is easier to clean
a good warming of the meat with a groove

- time-saving in food preparation
- easy preparation of good-looking food

7

Cooking unit for use on a table or on a base

variable use
the possibility of placement in smaller spaces

- easy handling
- cost savings on substructure

Technical data sheet

Technical parameters



Fry-top griddle plate 80x45 gas chromed grooved without cabinet

Model	SAP Code
	00001136

1. SAP Code:

00001136

2. Net Width [mm]:

800

3. Net Depth [mm]:

600

4. Net Height [mm]:

280

5. Net Weight [kg]:

73.00

6. Gross Width [mm]:

830

7. Gross depth [mm]:

690

8. Gross Height [mm]:

610

9. Gross Weight [kg]:

83.00

10. Device type:

Gas unit

11. Construction type of device:

Table top

12. Power gas [kW]:

12.000

13. Ignition:

Piezo + večný plamen

14. Type of gas:

Natural gas, propane butane

15. Protection of controls:

IPX5

16. Device color:

Stainless steel

17. Material:

AISI 304 top plate and cladding

18. Worktop material:

Super chrom

19. Worktop Thickness [mm]:

2.50

20. Service accessibility:

Trough the frontal panel

21. Safety thermocouple:

Yes

22. Adjustable feet:

Yes

23. Griddle dimensions [mm x mm]:

795 x 450

24. Griddle thickness [mm]:

14.00

25. Top type:

Grooved