

Technical data sheet

Product features



Cooking range electric 2x plate on open cabinet 400 V

Model	SAP Code	00002977
--------------	-----------------	----------



- Device type: Electric unit
- Power consumption of the zone 1 [kW]: 2,6
- Power consumption of the zone 2 [kW]: 2,6
- Protection of controls: IPX5
- Material: Stainless steel

SAP Code	00002977	Power electric [kW]	5.200
Net Width [mm]	400	Loading	400 V / 3N - 50 Hz
Net Depth [mm]	705	Number of zones	2
Net Height [mm]	900	Power consumption of the zone 1 [kW]	2,6
Net Weight [kg]	36.00	Power consumption of the zone 2 [kW]	2,6

Technical data sheet

Technical drawing



Cooking range electric 2x plate on open cabinet 400 V

Model

SAP Code

00002977

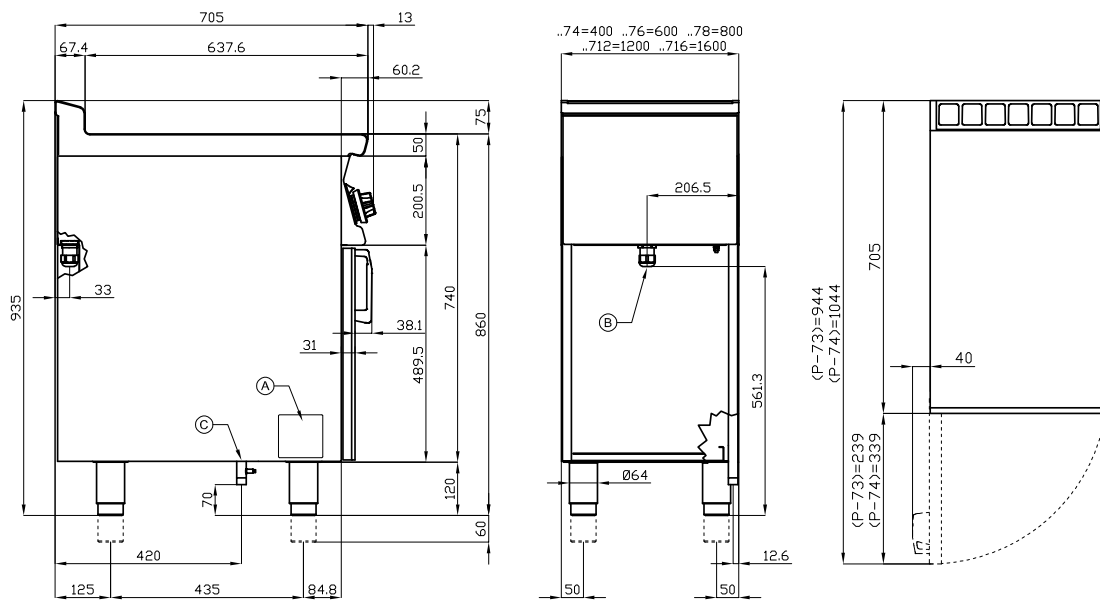

A	Data plate	B	Electrical connection
---	------------	---	-----------------------

Technical data sheet

Product benefits



Cooking range electric 2x plate on open cabinet 400 V

Model

SAP Code

00002977

1

Internal thermostatic plate protection

longer service life of the plates
– no overheating of the plates and no cracking

2

Degree of protection of the control elements IPX5

maintenance-free system
resistance to splash water
long life
– savings on service interventions
– easy cleaning and maintenance of equipment

3

All-stainless design

the material does not cut
wear resistance of the material
long life
– savings on service interventions
– easy cleaning and maintenance of equipment

4

Hygienic moldings of the top plate

absence of sharp corners and edges (potential places where dirt could stick)
smooth transitions
– easy quick cleaning

5

Square cast iron plates

durable square-shaped cast-iron plates
– larger plates with higher output
– also suitable for atypical vessels

Technical data sheet

Technical parameters



Cooking range electric 2x plate on open cabinet 400 V

Model

SAP Code

00002977

1. SAP Code:

00002977

2. Net Width [mm]:

400

3. Net Depth [mm]:

705

4. Net Height [mm]:

900

5. Net Weight [kg]:

36.00

6. Gross Width [mm]:

430

7. Gross depth [mm]:

770

8. Gross Height [mm]:

1110

9. Gross Weight [kg]:

46.00

10. Device type:

Electric unit

11. Construction type of device:

With substructure

12. Power electric [kW]:

5.200

13. Loading:

400 V / 3N - 50 Hz

14. Protection of controls:

IPX5

15. Material:

Stainless steel

16. Worktop type:

Molded - comfortable cleaning maintenance

17. Worktop material:

AISI 304

18. Worktop Thickness [mm]:

2.00

19. Number of zones:

2

20. Power consumption of the zone 1 [kW]:

2,6

21. Power consumption of the zone 2 [kW]:

2,6

22. Maximum device temperature [°C]:

300

23. Minimum device temperature [°C]:

50

24. Number of power control stages:

7

25. Service accessibility:

From the front by removing the front panel and waste fluid containers

26. Safety element:

internal thermostatic protection of the hotplate against overheating

Technical data sheet

Technical parameters



Cooking range electric 2x plate on open cabinet 400 V

Model	SAP Code	00002977
--------------	-----------------	----------

27. Safety thermostat:

Yes

30. Number of burners/hot plates:

2

28. Adjustable feet:

Yes

31. Type of electric cooking zones:

Squared

29. Additional information:

door not included - can be purchased