

Technical data sheet

Product features



Electric fryer 2 baskets 0,92 kW/l, 18+18 l on cabinet 400 V

Model	SAP Code	00000810
--------------	-----------------	----------



- Basin volume [l]: 18
- Drain type: Trough the cabinet
- Drain: Yes
- Safety drain: Yes
- Maximum device temperature [°C]: 190
- Minimum device temperature [°C]: 50
- Material: Stainless steel
- Ignition: Electric
- Number of baskets: 2
- Basket dimensions [mm x mm x mm]: 280 x 290 x 150

SAP Code	00000810	Basin volume [l]	18
Net Width [mm]	800	Number of basins	2
Net Depth [mm]	705	Number of baskets	2
Net Height [mm]	900	Basket dimensions [mm x mm x mm]	280 x 290 x 150
Net Weight [kg]	84.00	Ratio power/volume [kW/l]	0.92
Power electric [kW]	31.800	Production of fries [kg/h]	30
Loading	400 V / 3N - 50 Hz		

Technical data sheet

Technical drawing



Electric fryer 2 baskets 0,92 kW/l, 18+18 l on cabinet 400 V

Model

SAP Code

00000810

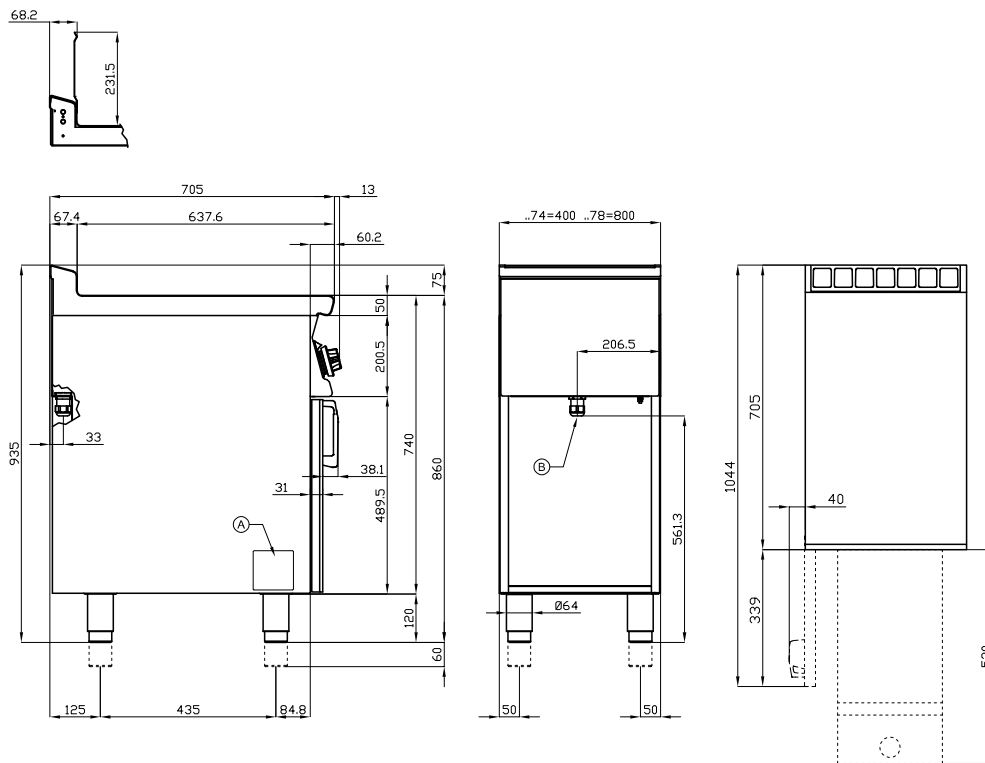

A	Data plate	B	Electrical connection
---	------------	---	-----------------------

Technical data sheet

Product benefits



Electric fryer 2 baskets 0,92 kW/l, 18+18 l on cabinet 400 V

Model

SAP Code

00000810

1

All-stainless steel bathtub

long life
resistance of AISI 304 stainless steel material
the material does not cut

- savings on service interventions
- easier and faster operation

2

Degree of protection of the control elements IPX5

maintenance-free system
resistance to splash water
long life

- savings on service interventions
- easy cleaning and maintenance of equipment

3

Outlet into a removable collector in the base with a sieve against coarse dirt

outlet of the bath into the prepared container

- easy and safe handling

4

Cold zone

prevents food residues from burning
there is no change in the taste of the oil

- longer oil life
- easy access and maintenance

5

Rotating heating element

longer lifetime
easy access

- effective cleaning when the body is tipped out
- easy access even to corners and time saving

6

Protective grate above the heating elements

preventing direct contact of the frying basket with the heating element

- longer life of the heating element
- safer handling of the basket on a flat surface

7

Prevention of spontaneous combustion

higher rear chimney

- safer heat dissipation and separation of oil and ventilation from the fryer

8

2 thermostats

safety and working thermostat

- traffic safety
- prevention of spontaneous combustion
- Prevention of oil flashover

Technical data sheet

Technical parameters



Electric fryer 2 baskets 0,92 kW/l, 18+18 l on cabinet 400 V

Model

SAP Code

00000810

1. SAP Code:

00000810

2. Net Width [mm]:

800

3. Net Depth [mm]:

705

4. Net Height [mm]:

900

5. Net Weight [kg]:

84.00

6. Gross Width [mm]:

830

7. Gross depth [mm]:

770

8. Gross Height [mm]:

1110

9. Gross Weight [kg]:

97.00

10. Device type:

Electric unit

11. Construction type of device:

With substructure

12. Power electric [kW]:

31.800

13. Loading:

400 V / 3N - 50 Hz

14. Ignition:

Electric

15. Protection of controls:

IPX5

16. Material:

Stainless steel

17. Indicators:

operation and warm-up

18. Worktop type:

Molded - comfortable cleaning maintenance

19. Worktop material:

Stainless steel

20. Standard equipment for device:

2 x lid and 1 x basket included in the package - option to purchase baskets in other sizes, 2 containers

21. Basin volume [l]:

18

22. Maximum device temperature [°C]:

190

23. Minimum device temperature [°C]:

50

24. Power control type:

knob control

25. Safety element:

safety element "thermocouple"
outlet safety fuse

26. Safety thermostat:

Yes

Technical data sheet

Technical parameters



Electric fryer 2 baskets 0,92 kW/l, 18+18 l on cabinet 400 V

Model

SAP Code

00000810

27. Adjustable feet:

Yes

28. Heating element material:

AISI 304

29. Number of baskets:

2

30. Number of basins:

2

31. Basket dimensions [mm x mm x mm]:

280 x 290 x 150

32. Ratio power/volume [kW/l]:

0.92

33. Production of fries [kg/h]:

30

34. Heating element construction:

AISI 304 swivel heating element allows easy cleaning of the pan

35. Drain type:

Trough the cabinet

36. Drain:

Yes

37. Safety drain:

Yes