

Technical data sheet

Product features



Multi-function fixed braising pan electric 12 l cabinet with door 400 V

Model	SAP Code	00000128
--------------	-----------------	----------



- Bottom material: Stainless steel - suitable for cooking, easy maintenance
- Bottom thickness: 16.00
- Basin volume [l]: 12
- Protection of controls: IPX5
- Basin dimensions [mm x mm x mm]: 300 x 420 x 100
- Service accessibility: Trough the frontal panel

SAP Code	00000128	Loading	400 V / 3N - 50 Hz
Net Width [mm]	400	Bottom material	Stainless steel - suitable for cooking, easy maintenance
Net Depth [mm]	600	Basin volume [l]	12
Net Height [mm]	900	Width of internal part [mm]	300
Net Weight [kg]	65.00	Depth of internal part [mm]	420
Power electric [kW]	3.300	Height of internal part [mm]	100

Technical data sheet

Technical drawing



Multi-function fixed braising pan electric 12 l cabinet with door 400 V

Model	SAP Code	00000128
--------------	-----------------	----------

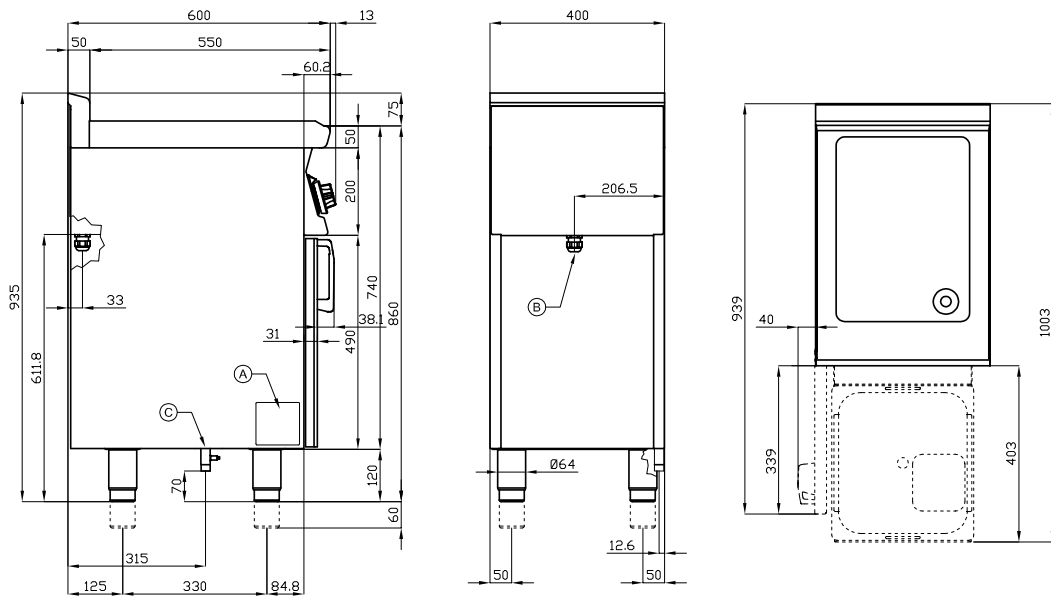

A	Data plate		B	Electrical connection	
---	------------	--	---	-----------------------	--

Technical data sheet

Product benefits



Multi-function fixed braising pan electric 12 l cabinet with door 400 V

Model	SAP Code	00000128
--------------	-----------------	----------

1

All-stainless steel bathtub

long life
resistance of AISI 304 stainless steel material
the material does not cut

- savings on service interventions
- easier and faster operation

2

Degree of protection of the control elements IPX5

maintenance-free system
resistance to splash water
long life

- savings on service interventions
- easy cleaning and maintenance of equipment

3

Outlet to a removable collector in the substructure

outlet of the bath into the prepared container

- easy and safe handling

Technical data sheet

Technical parameters



Multi-function fixed braising pan electric 12 l cabinet with door 400 V

Model

SAP Code

00000128

1. SAP Code:

00000128

2. Net Width [mm]:

400

3. Net Depth [mm]:

600

4. Net Height [mm]:

900

5. Net Weight [kg]:

65.00

6. Gross Width [mm]:

430

7. Gross depth [mm]:

670

8. Gross Height [mm]:

1110

9. Gross Weight [kg]:

75.00

10. Device type:

Electric unit

11. Construction type of device:

With substructure

12. Power electric [kW]:

3.300

13. Loading:

400 V / 3N - 50 Hz

14. Protection of controls:

IPX5

15. Device color:

Stainless steel

16. Material:

AISI 304 top plate and cladding

17. Indicators:

operation and warm-up

18. Worktop Thickness [mm]:

1.00

19. Basin volume [l]:

12

20. Basin dimensions [mm x mm x mm]:

300 x 420 x 100

21. Device capacity [l]:

12.00

22. Maximum device temperature [°C]:

300

23. Minimum device temperature [°C]:

50

24. Service accessibility:

Trough the frontal panel

25. Safety thermostat:

Yes

26. Adjustable feet:

Yes

27. Bottom thickness:

16.00

28. Bottom material:

Stainless steel - suitable for cooking, easy maintenance

Technical data sheet

Technical parameters



Multi-function fixed braising pan electric 12 l cabinet with door 400 V

Model

SAP Code

00000128

29. Drain:

Yes

31. Depth of internal part [mm]:

420

30. Width of internal part [mm]:

300

32. Height of internal part [mm]:

100