

RM 900
 Platný od 1.5. 2019
 CF6-912G

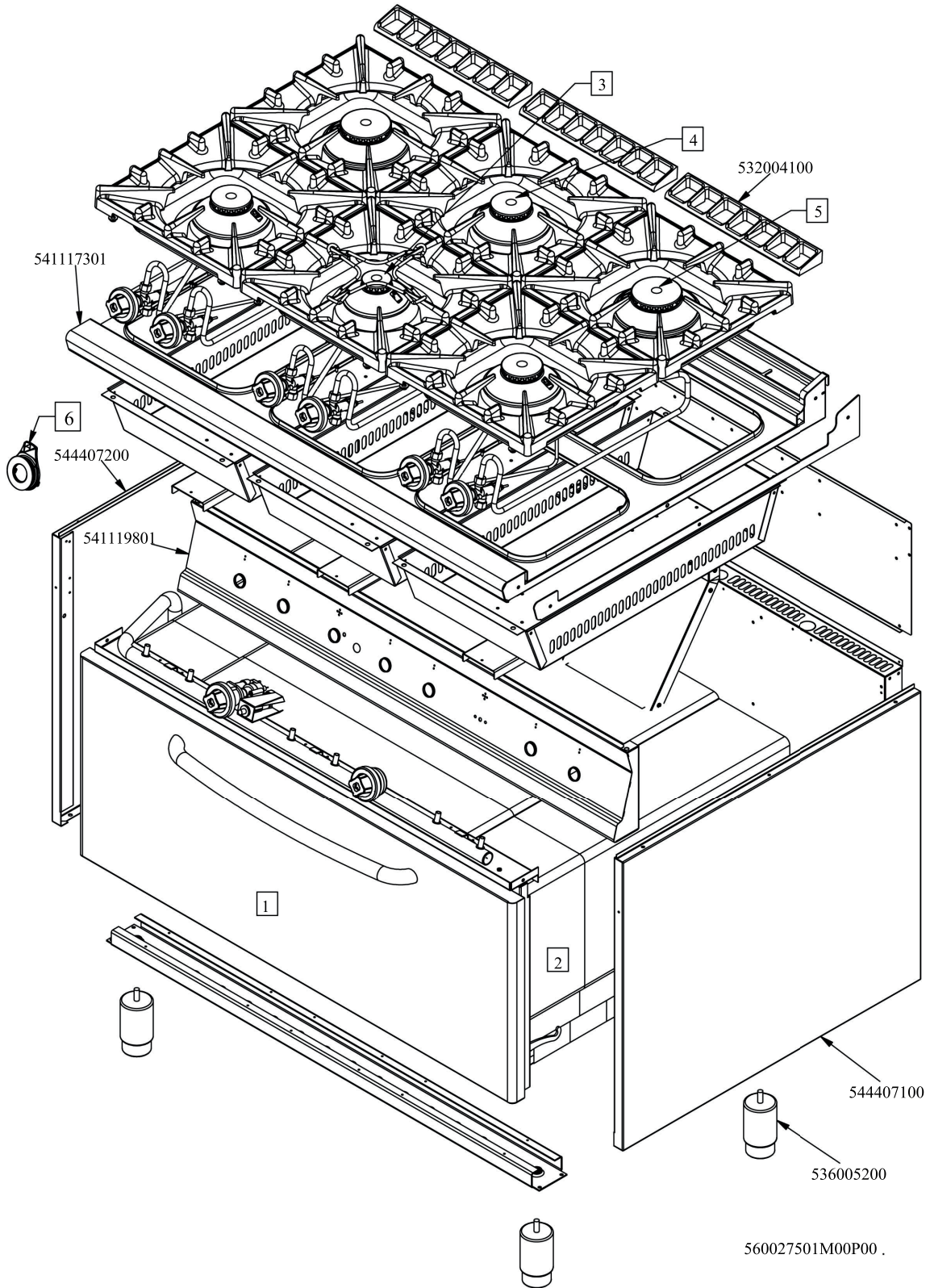

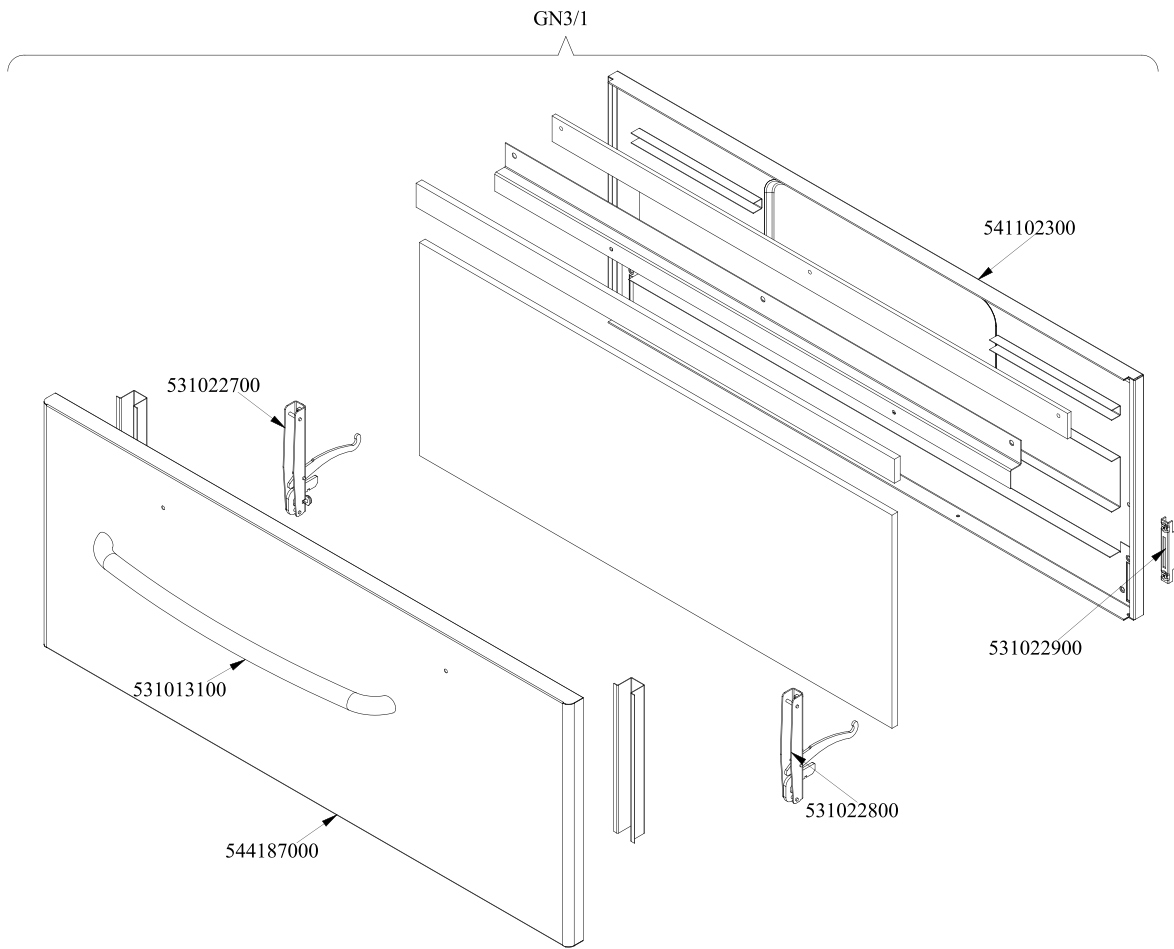

560099900M01P00



Objednací kód	Popis v ENG
541102300	GAS OVEN INNER DOOR GN 3/1 S.70
531022800	531022800N DOOR HINGE S.70
531022900	HINGE ROLLER HOLDER FOR 700-OVEN
531013100	OVEN DOOR HANDLE OF 70/90-LINE
531022700	LEFT OVEN DOOR HINGE 70LINE
544187000	OVEN DOOR GN 3/1 S.70

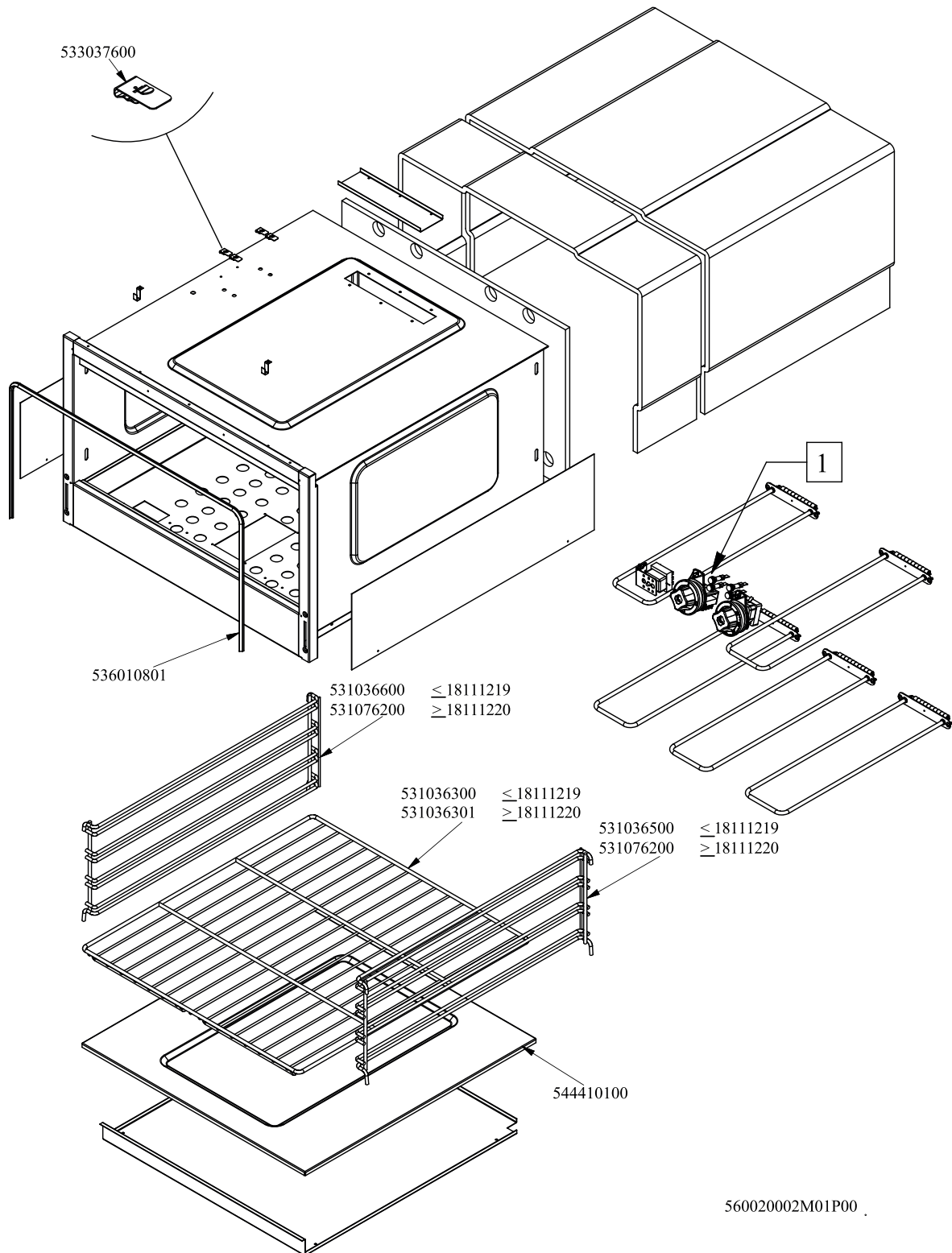



Objednačí kód	Popis v ENG
531036600	LHD RACK HOLDER FOR OVEN S.90
531076200	
531036300	OVEN RACK GN 2/1 FOR 90 LINE
531036301	OVEN RACK GN 2/1 FOR 90 LINE
544410100	90 ELECTRICAL OVEN BOTTOM GN2/1
533037600	LOCK SPRING FOR BULB
531036500	RHD RACK HOLDER FOR OVEN S.90
536010801	OVEN GASKET GN 2/1 (1308)
-	-

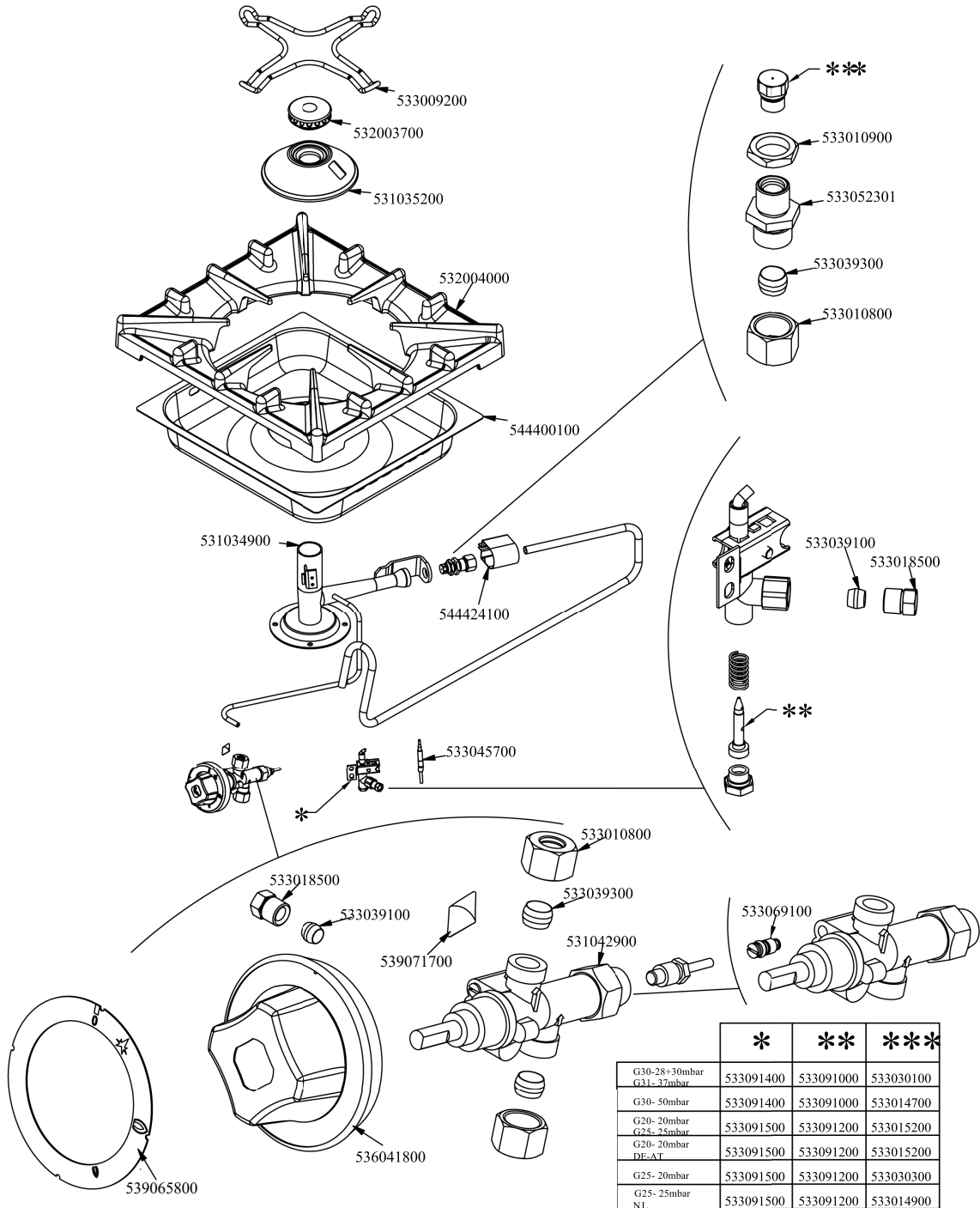



Objednačí kód	Popis v ENG
533030100	NOZZLE §95 CH12*14 G-FP
533014700	NOZZLE §85 CH12*14 F-FQ5
533015200	NOZZLE §145 CH12*14 F-FP/CP6
533030300	NOZZLE §160 CH12*14 M-FPG
533014900	NOZZLE §150 CH12*14 F-FQ5 L-FQ6
533091000	NOZZLE 0.100 §20
533091200	PILOT NOZZLE 0100 Ø35 PIL.PC
533091400	P.NOZZLE S100 UG.§20 PC90 LPG-FLUS
533091500	PILOT NOZZLE S.100 §30 PC90 NAT.GAS
539065800	BLACK STICKING DISK 72
536041800	SILVER CHROM. KNOB Ø77 4P.G.Ø08X6,5
533039300	BICONE §10
533010800	TUBE NUT D.10 M16*1,5
531042900	B.PASS §60 SAFETY COCK PC/CF 90
533009200	REDUCTION GRATE FOR 65-70LINES+FO
532003700	BURNER COVER RING §060
531035200	SMALL BURNER BODY 90 LINE
532004000	1 FLAME GRILL 396X366 (90)
544400100	BURNER DRIP PAN 2/3
531034900	SMALL BURNER VENTURI 90 LINE
533018500	FITTING FOR BICONE D.6 M10*1
533039100	BICONE §6
539071700	ADHES.LABEL FOR RING GREEN SIGN.
544424100	AIR ADJUSTMENT BUSHING*BURNER PC90
533045700	THERMOCOUPLE M9*1 500
533069100	BY PASS COCK §60 20S
533052301	JOINT FOR NOZZLE HOLDER
533010900	NUT M14*1 H.4

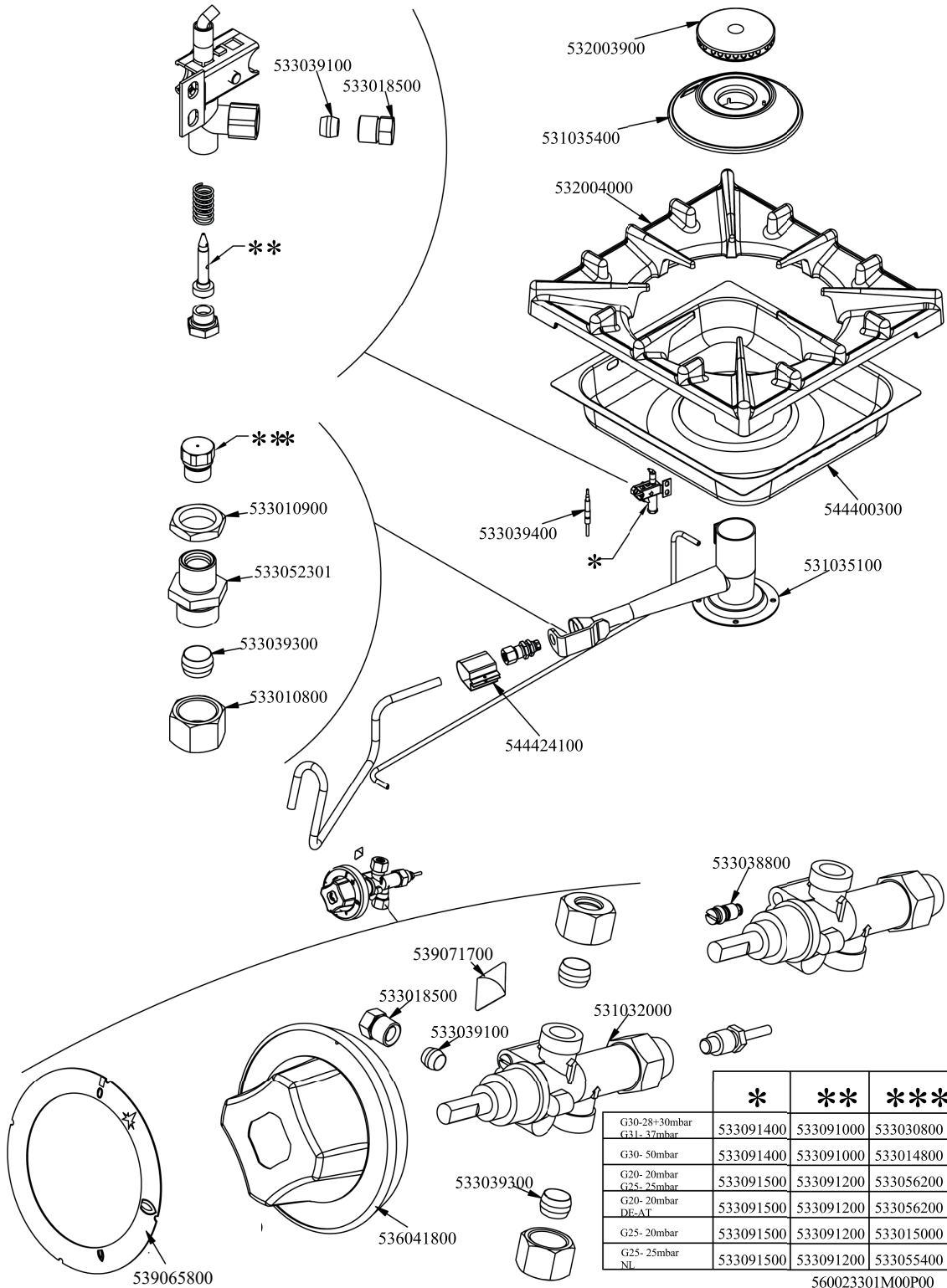



Objednací kód	Popis v ENG
537027802	HEATING ELEMENT S90 S.0800W 1-230V
537012800	SAFETY THERMOSTAT 420°C THREEPHASE
537000900	THERMOSTAT 063-320°C THREEPHASE
539071100	
537014101	WHITE WARNING LIGHT 250V
533023600	TAP PLUG §10 M16*1, 5CH19
533039300	BICONE §10
533010800	TUBE NUT D.10 M16*1,5
537027902	
537028002	
537028102	HEATING ELEMENT 90S I.1700W 1-230V
537028202	
537028302	
536041700	SILVER CHROM. KNOB Ø77 4P.G.Ø06X4,6
539062000	ADESIVE DISK THERMOSTAT OVEN S70
539061900	ADESIVE DISK FOR SWITCH OVEN S70
537035400	HEATING ELEMENT 00003W 330KOHM W/F
533093300	LOCKING PIN SWITCH S.43 THERMOST
537000400	COMMUTATOR 1POS.SINGLEPHASE S49 16A
537014201	GREEN WARNING LIGHT 250V
537034001	COMMUTATOR 4 POS.3PHASE S.42 16A
539070200	

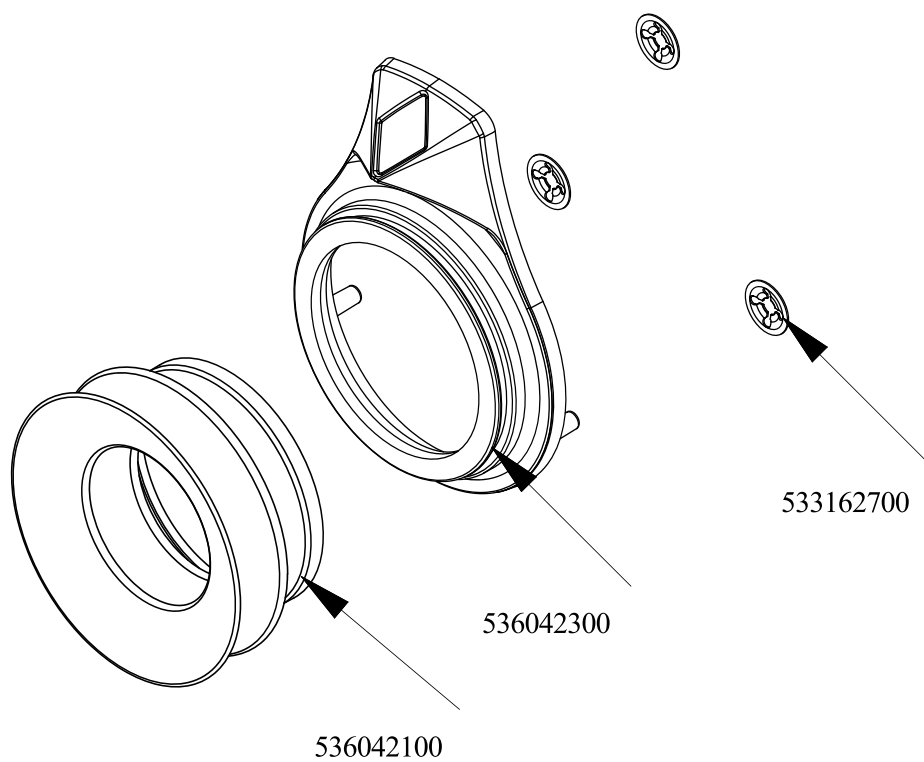

560125700M00P00



Objednačí kód	Popis v ENG
536042300	SILVER CHROM. RING FOR KNOB Ø77 4 P
536042100	SEAL CASING FOR KNOB Ø77 4 P
533162700	PROCESSING CODE



CF6 - 912 G
Platnost
1.5.2016 do
30.4.2019

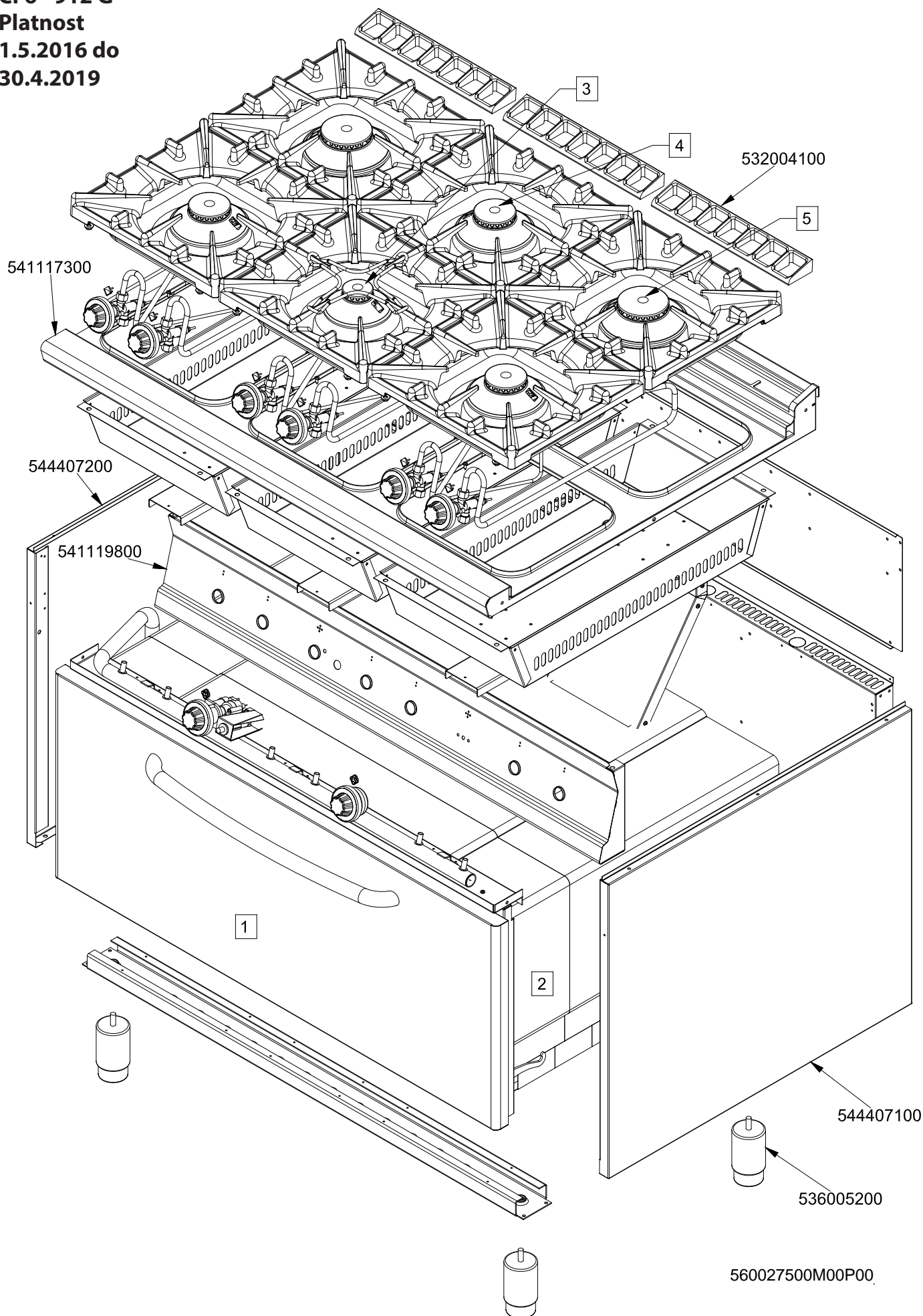

CF6 - 912 G

(1)

Platnost

1.5.2016 do

30.4.2019

GN 2/1

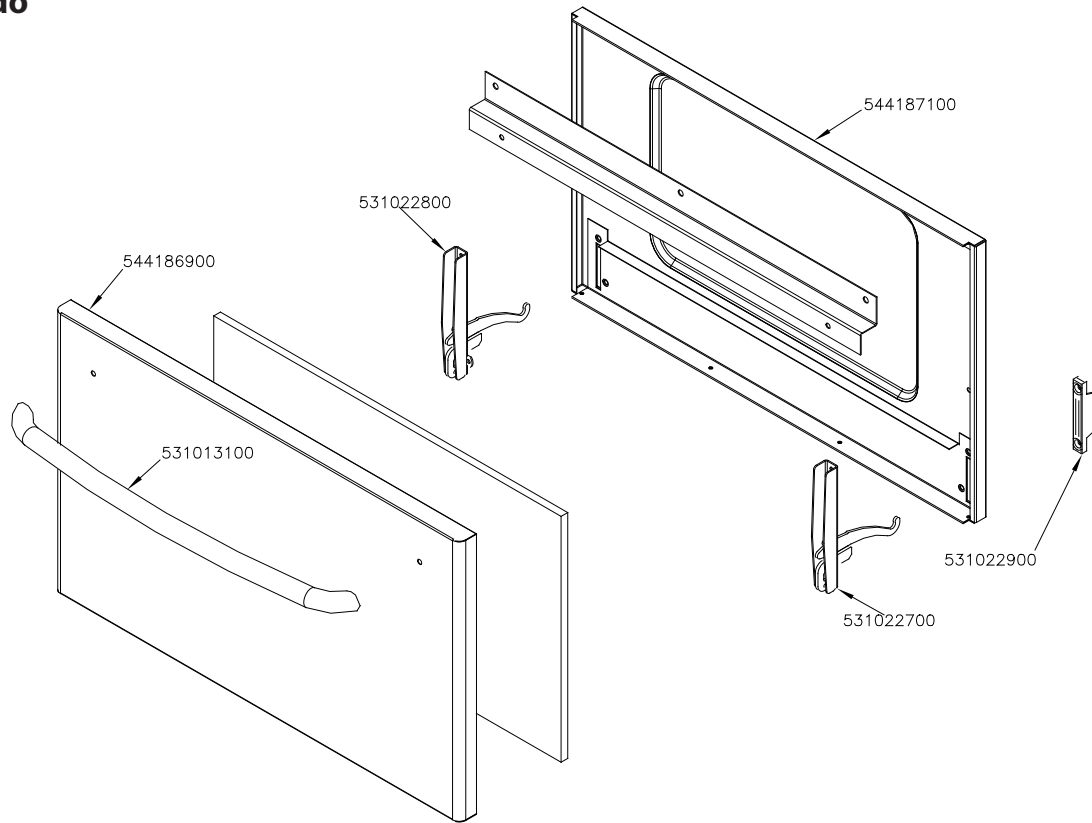

GN 3/1

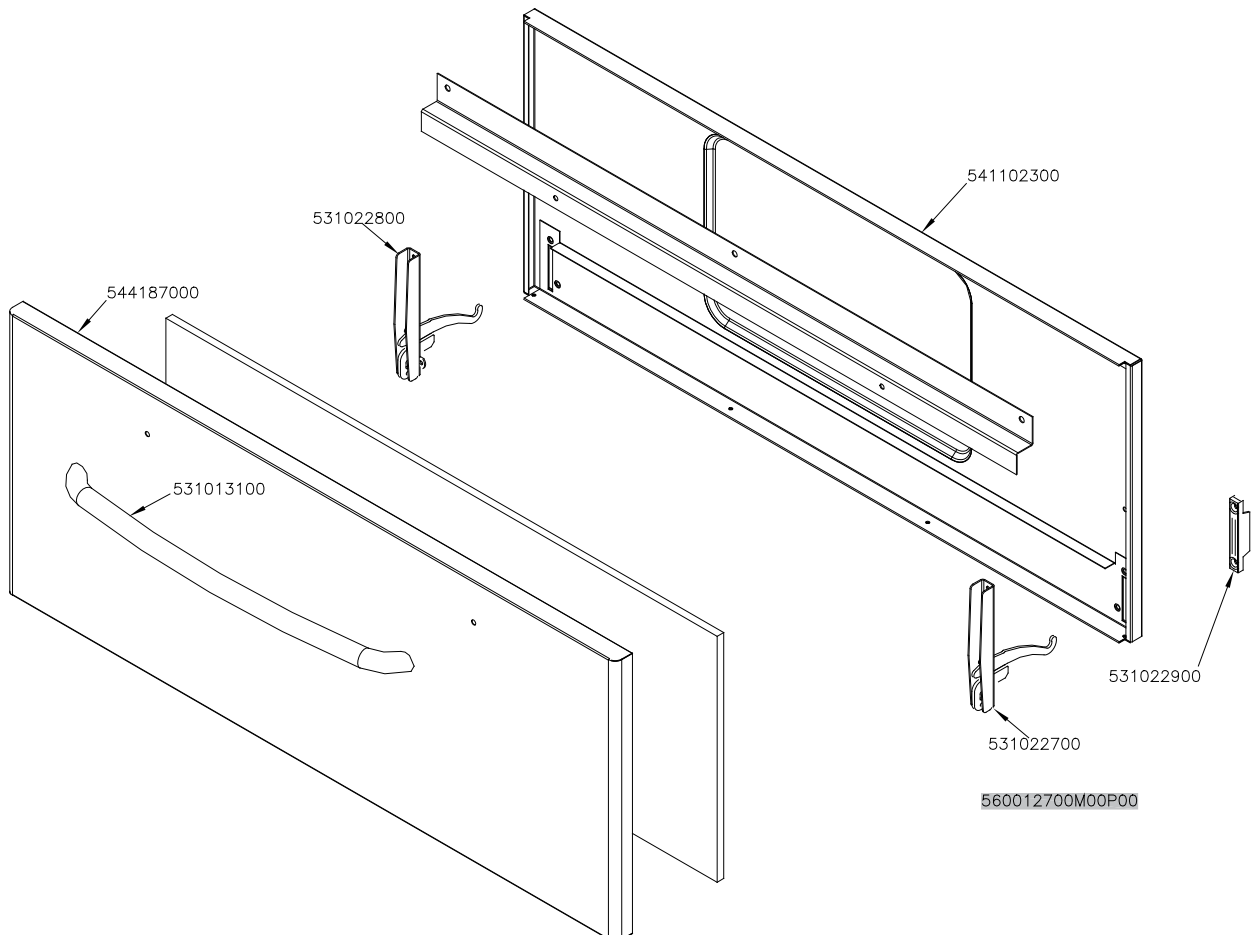



CF6 - 912 G

(2)

Platnost

1.5.2016 do

30.4.2019

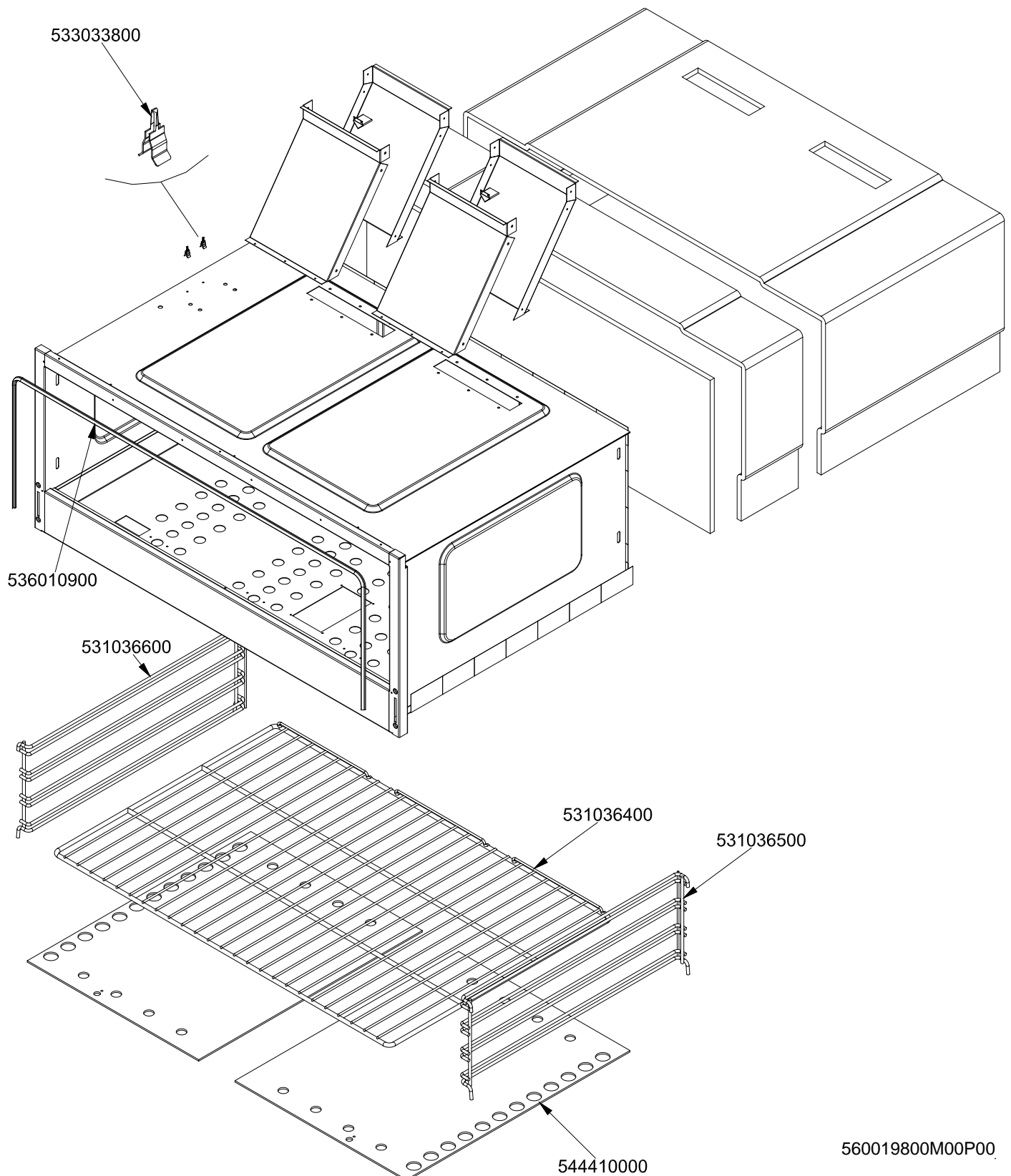



CF6 - 912 G
Platnost
1.5.2016 do
30.4.2019

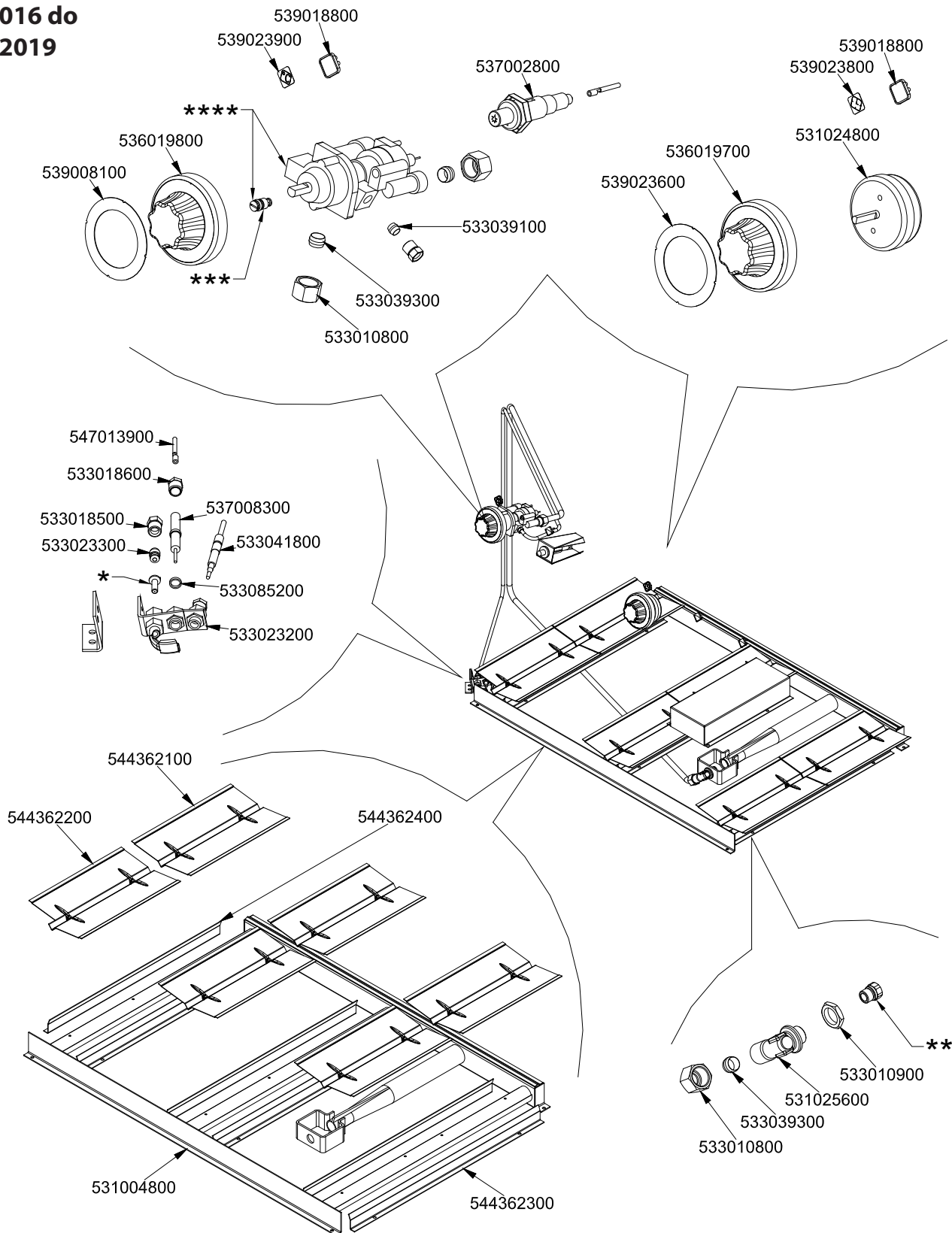

	*	**	***	****
G30-28+30mbar G31- 37mbar	533020500	533019400	533069300	531034000
G30- 50mbar	533020500	533030300	533069500	531033900
G20- 20mbar G25- 25mbar	533020600	533055700	533069300	531034000
G20- DE-AT	533020600	533055700	533069500	531033900
G25- 20mbar	533020600	533056400	533069500	531033900
G25- 25mbar NL	533020600	533056000	533069300	531034000



CF6 - 912 G
4 kW
Platnost
1.5.2016 do
30.4.2019

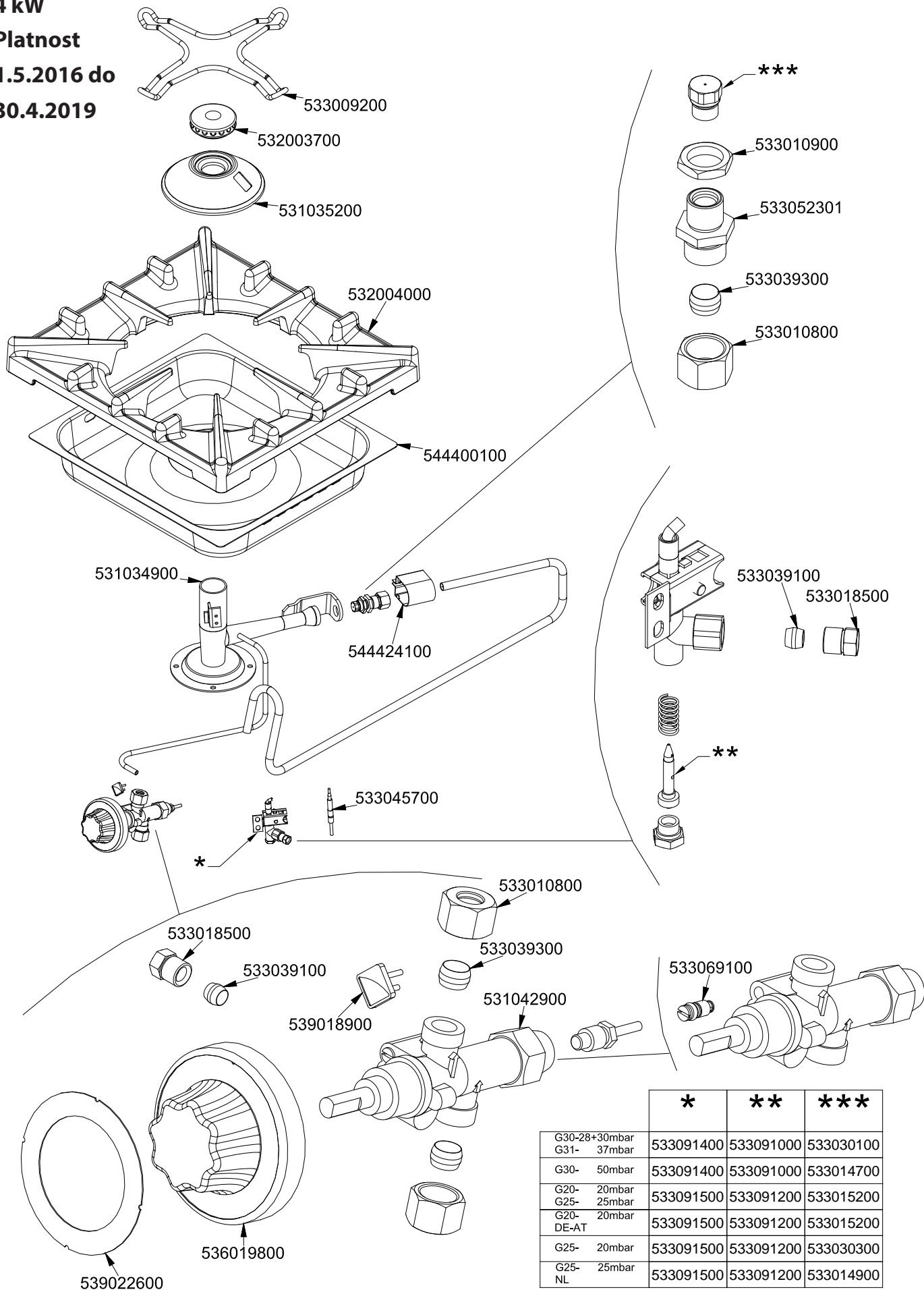

	*	**	***
G30-28+30mbar G31- 37mbar	533091400	533091000	533030100
G30- 50mbar	533091400	533091000	533014700
G20- 20mbar G25- 25mbar	533091500	533091200	533015200
G20- DE-AT	533091500	533091200	533015200
G25- 20mbar	533091500	533091200	533030300
G25- NL	533091500	533091200	533014900



CF6 - 912 G

7 kW

Platnost

1.5.2016 do

30.4.2019

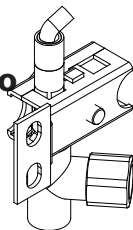

533039100

533018500

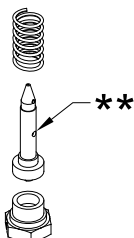

**

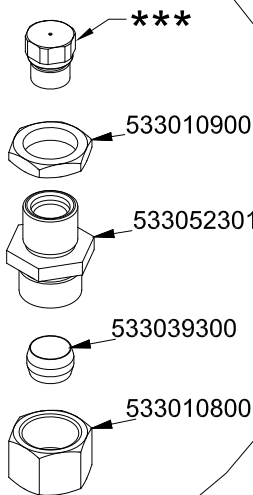

533010900

533052301

533039300

533010800

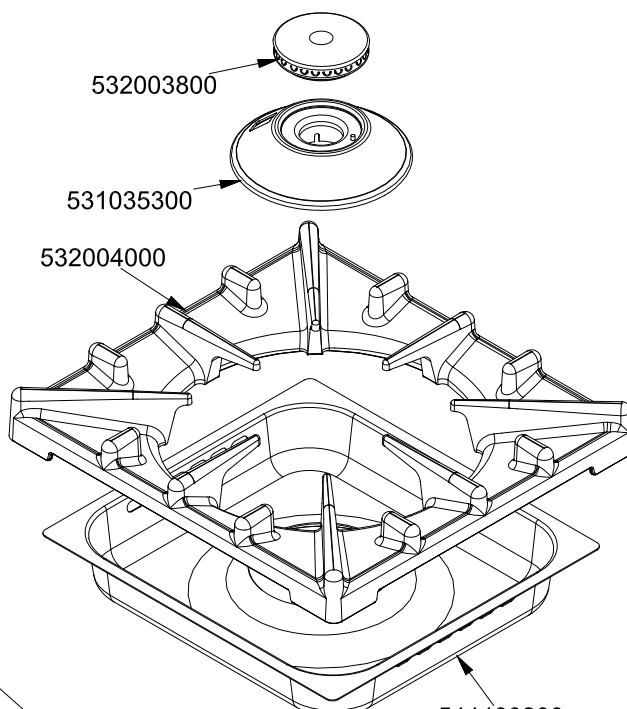

532003800

531035300

532004000

544400200

531035000

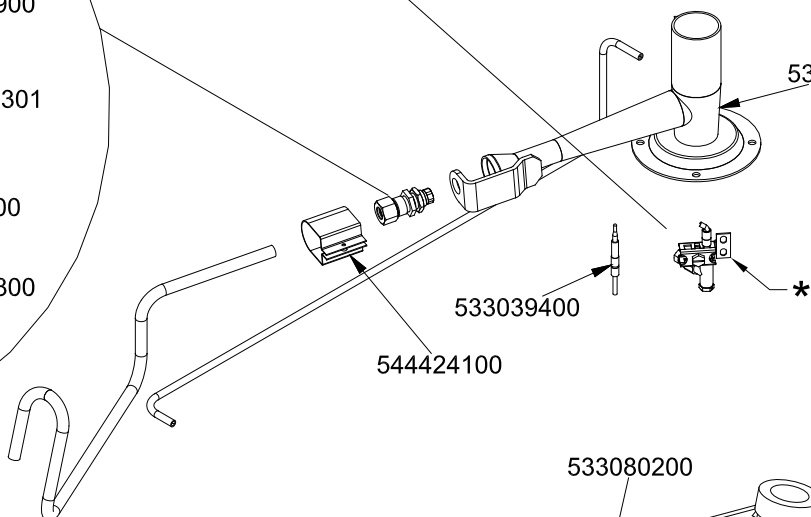

533039400

544424100

*



533080200

539018900

531043000

533018500

533039100

533039300

533010800

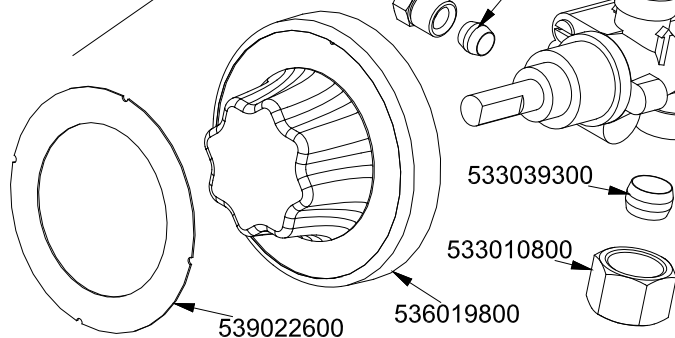

539022600

536019800

	*	**	***
G30-28+30mbar	533091400	533091000	533043800
G31- 37mbar	533091400	533091000	533043900
G30- 50mbar	533091500	533091200	533044000
G20- 20mbar	533091500	533091200	533044000
G25- 25mbar	533091500	533091200	533055100
G20- 20mbar	533091500	533091200	533055000
DE-AT			
G25- 20mbar			
G25- 25mbar			
NL			

560023200M00P00



CF6 - 912 G
10 kW
Platnost
1.5.2016 do
30.4.2019

