

Technical data sheet

Product features



Fry-top griddle plate 59x52 electric chromed combined on open cabinet 400 V

Model	SAP Code	00001045
--------------	-----------------	----------



- Top type: Combined
- Griddle dimensions [mm x mm]: 560 x 510
- Griddle thickness [mm]: 14.00
- Worktop material: Super chrom
- Container for liquid fat: Yes
- Maximum device temperature [°C]: 300
- Removable rim: Yes

SAP Code	00001045	Power electric [kW]	7.400
Net Width [mm]	600	Loading	400 V / 3N - 50 Hz
Net Depth [mm]	705	Griddle dimensions [mm x mm]	560 x 510
Net Height [mm]	900	Top type	Combined
Net Weight [kg]	72.00	Worktop type	Molded - comfortable cleaning maintenance

Technical data sheet

Technical drawing



Fry-top griddle plate 59x52 electric chromed combined on open cabinet 400 V

Model

SAP Code

00001045

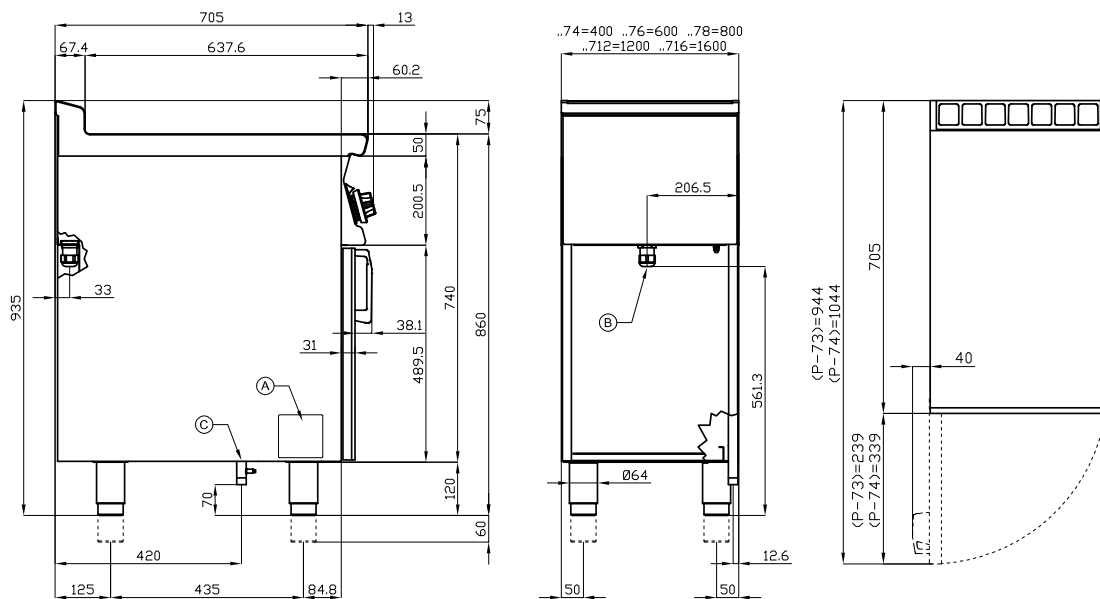

A	Data plate	B	Electrical connection
---	------------	---	-----------------------

Technical data sheet

Product benefits



Fry-top griddle plate 59x52 electric chromed combined on open cabinet 400 V

Model

SAP Code

00001045

1

All-stainless design

long life
resistance of AISI 304 stainless steel material
the material does not cut

- savings on service interventions
- easier and faster operation

2

Degree of protection of the control elements IPX5

maintenance-free system
resistance to splash water
long life

- savings on service interventions
- easy cleaning and maintenance of equipment

3

Outlet for waste liquids

ensures that oil drips into the socket

- easy maintenance
- easy cleaning

4

High detachable hem

better hygienic conditions
preventing grease from splashing onto ancillary equipment

- easy maintenance
- easy cleaning

5

Combined plate made of chrome-plated steel

the product bakes less
enables preparation on smooth or grooved plates

- time-saving in food preparation
- easy preparation of different types of dishes

6

Outlet for waste liquids

ensures that oil drips into the socket

- easy maintenance
- easy cleaning

7

Combined grilling area

straight and grooved grid

- the possibility of preparing several types of gastronomic treatments at the same time
- separate control of each area

8

Surface treatment "Superchrom"

a thicker layer of protective chrome applied with new technology

- the top is more scratch resistant
- more convenient and faster handling of food on the plate
- the possibility of preparing more delicate types of food
- the plate does not get dirty, does not swell

Technical data sheet

Technical parameters



Fry-top griddle plate 59x52 electric chromed combined on open cabinet 400 V

Model

SAP Code

00001045

1. SAP Code:

00001045

2. Net Width [mm]:

600

3. Net Depth [mm]:

705

4. Net Height [mm]:

900

5. Net Weight [kg]:

72.00

6. Gross Width [mm]:

630

7. Gross depth [mm]:

770

8. Gross Height [mm]:

1110

9. Gross Weight [kg]:

78.00

10. Device type:

Electric unit

11. Construction type of device:

Stationary

12. Power electric [kW]:

7.400

13. Loading:

400 V / 3N - 50 Hz

14. Protection of controls:

IPX5

15. Device color:

Stainless steel

16. Material:

Stainless steel

17. Indicators:

operation and warm-up

18. Worktop type:

Molded - comfortable cleaning maintenance

19. Worktop material:

Super chrom

20. Worktop Thickness [mm]:

2.00

21. Maximum device temperature [°C]:

300

22. Minimum device temperature [°C]:

50

23. Power control type:

knob control

24. Service accessibility:

Trough the frontal panel

25. Safety element:

safety thermostat

26. Safety thermostat:

Yes

27. Adjustable feet:

Yes

28. Additional information:

door not included - can be purchased

Technical data sheet

Technical parameters



Fry-top griddle plate 59x52 electric chromed combined on open cabinet 400 V

Model

SAP Code

00001045

29. Griddle dimensions [mm x mm]:

560 x 510

32. Removable rim:

Yes

30. Griddle thickness [mm]:

14.00

33. Uniform heating:

Yes

31. Container for liquid fat:

Yes

34. Top type:

Combinated