

Technical data sheet



Product features

Fry-top griddle plate 40x51 electric grooved without cabinet 400 V

Model	SAP Code	00110068
--------------	-----------------	----------



- Top type: Grooved
- Griddle dimensions [mm x mm]: 400 x 510
- Griddle thickness [mm]: 12.00
- Worktop material: Sandblasted steel
- Container for liquid fat: Yes
- Maximum device temperature [°C]: 300
- Surface finish: sandblasted surface without coating
- Removable rim: Yes

SAP Code	00110068	Power electric [kW]	4.500
Net Width [mm]	400	Loading	400 V / 3N - 50 Hz
Net Depth [mm]	700	Griddle dimensions [mm x mm]	400 x 510
Net Height [mm]	330	Top type	Grooved
Net Weight [kg]	36.00		

Technical data sheet



Technical drawing

Fry-top griddle plate 40x51 electric grooved without cabinet 400 V

Model	SAP Code	00110068
-------	----------	----------

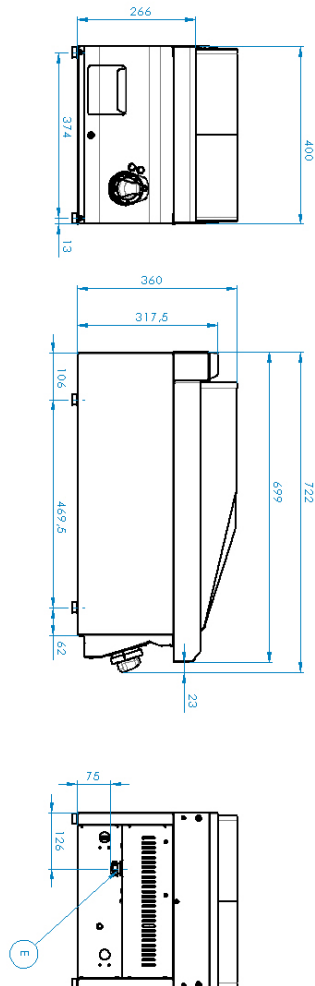

Technical data sheet



Product benefits

Fry-top griddle plate 40x51 electric grooved without cabinet 400 V

Model

SAP Code

00110068

1

All-stainless design

- long life
- corrosion resistance of the top plate material
 - savings on service interventions
 - easier and faster operation

2

Degree of protection of the control elements IPX4

- maintenance-free system
- resistance to splash water
- long life
 - savings on service interventions
 - easy cleaning and maintenance of equipment

3

Outlet for waste liquids

- ensures that oil drips into the socket
 - easy maintenance
 - easy cleaning

4

High detachable hem

- better hygienic conditions
- preventing grease from splashing onto ancillary equipment
 - easy maintenance
 - easy cleaning

5

Ribbed steel plate

- fast heat transfer and the surface will not be scratched
- a good warming of the meat with a groove
 - time-saving in food preparation
 - easy preparation of good-looking food

6

Cooking unit for use on a table or on a base

- variable use
- the possibility of placement in smaller spaces
 - easy handling
 - cost savings on substructure

Technical data sheet



Technical parameters

Fry-top griddle plate 40x51 electric grooved without cabinet 400 V

Model	SAP Code	00110068
--------------	-----------------	----------

1. SAP Code:

00110068

2. Article group:

RF-Line 700

3. Net Width [mm]:

400

4. Net Depth [mm]:

700

5. Net Height [mm]:

330

6. Net Weight [kg]:

36.00

7. Gross Width [mm]:

440

8. Gross depth [mm]:

800

9. Gross Height [mm]:

390

10. Gross Weight [kg]:

42.00

11. Device type:

Electric unit

12. Construction type of device:

Table top

13. Power electric [kW]:

4.500

14. Loading:

400 V / 3N - 50 Hz

15. Protection of controls:

IPX4

16. Material:

AISI 304 top plate, AISI 430 cladding

17. Indicators:

operation and warm-up

18. Worktop material:

Sandblasted steel

19. Worktop Thickness [mm]:

1.20

20. Surface finish:

sandblasted surface without coating

21. Maximum device temperature [°C]:

300

22. Minimum device temperature [°C]:

50

23. Service accessibility:

Trough the frontal panel

24. Safety thermostat:

Yes

25. Adjustable feet:

Yes

26. Griddle dimensions [mm x mm]:

400 x 510

27. Griddle thickness [mm]:

12.00

28. Container for liquid fat:

Yes

Technical data sheet



Technical parameters

Fry-top griddle plate 40x51 electric grooved without cabinet 400 V

Model	SAP Code	00110068
--------------	-----------------	----------

29. Removable rim:

Yes

30. Top type:

Grooved