

# Technical data sheet

## Product features



### Fry-top griddle plate 56x55 drop-in electric combined 400 V

<b>Model</b>	<b>SAP Code</b>	00007460
--------------	-----------------	----------



- Top type: Combined
- Griddle dimensions [mm x mm]: 600 x 600
- Griddle thickness [mm]: 14.00
- Worktop material: Stainless steel
- Grid size [mm x mm]: 450 x 595
- Independent heating zones: Separate control for each heating zone
- Maximum device temperature [°C]: 300
- Removable rim: Yes

<b>SAP Code</b>	00007460	<b>Loading</b>	400 V / 3N - 50 Hz
<b>Net Width [mm]</b>	600	<b>Griddle dimensions [mm x mm]</b>	600 x 600
<b>Net Depth [mm]</b>	600	<b>Grid size [mm x mm]</b>	450 x 595
<b>Net Height [mm]</b>	220	<b>Top type</b>	Combined
<b>Net Weight [kg]</b>	45.00	<b>Worktop type</b>	Molded - comfortable cleaning maintenance
<b>Power electric [kW]</b>	6.000		

# Technical data sheet

Technical drawing



## Fry-top griddle plate 56x55 drop-in electric combined 400 V

Model

SAP Code

00007460

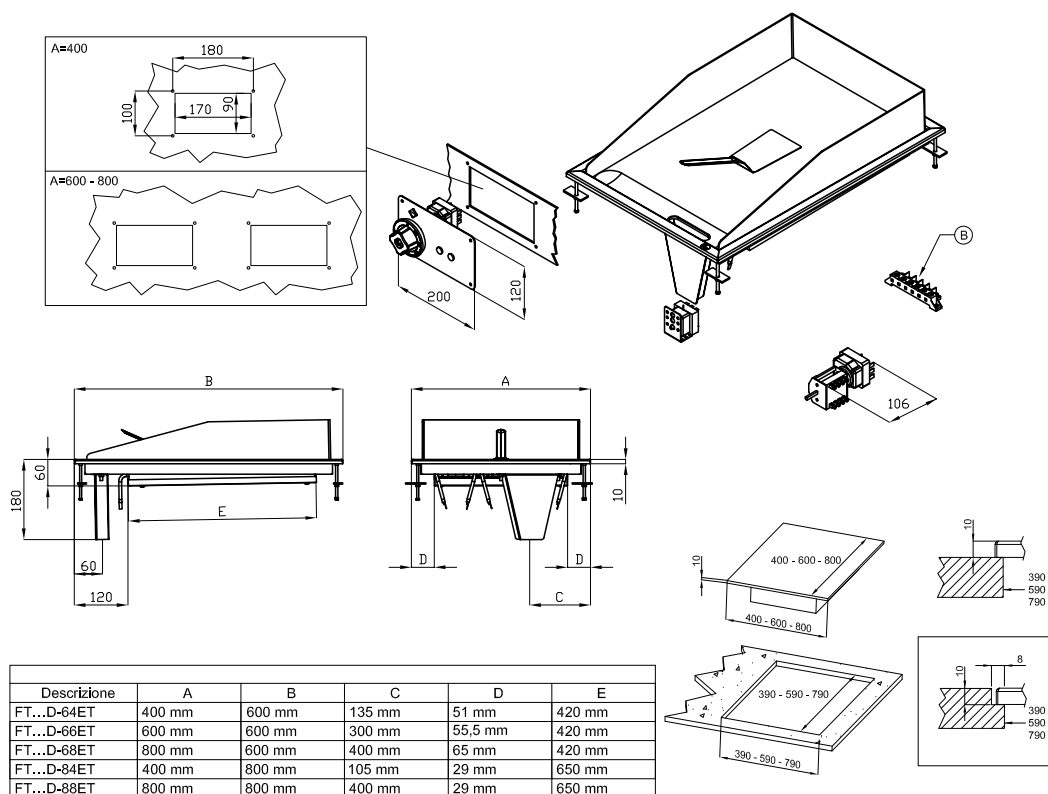

Descrizione	A	B	C	D	E
FT...D-64ET	400 mm	600 mm	135 mm	51 mm	420 mm
FT...D-66ET	600 mm	600 mm	300 mm	55,5 mm	420 mm
FT...D-68ET	800 mm	600 mm	400 mm	65 mm	420 mm
FT...D-84ET	400 mm	800 mm	105 mm	29 mm	650 mm
FT...D-88ET	800 mm	800 mm	400 mm	29 mm	650 mm

A	Data plate		B	Electrical connection	
---	------------	--	---	-----------------------	--

# Technical data sheet

## Product benefits



### Fry-top griddle plate 56x55 drop-in electric combined 400 V

Model

SAP Code

00007460

1

#### All-stainless design

long life  
resistance of AISI 304 stainless steel material  
the material does not cut

- savings on service interventions
- easier and faster operation

2

#### Degree of protection of the control elements IPX5

maintenance-free system  
resistance to splash water  
long life

- savings on service interventions
- easy cleaning and maintenance of equipment

3

#### Built-in cooking unit

variable use  
the possibility of placement in smaller spaces

- easy handling
- cost savings on substructure

4

#### High detachable hem

better hygienic conditions  
preventing grease from splashing onto  
ancillary equipment

- easy maintenance
- easy cleaning

5

#### Combined steel plate

good heat transfer and the surface does not get scratched  
enables preparation on smooth or grooved plates

- time-saving in food preparation
- easy preparation of different types of dishes

# Technical data sheet

## Technical parameters



### Fry-top griddle plate 56x55 drop-in electric combined 400 V

**Model**

**SAP Code**

00007460

**1. SAP Code:**

00007460

**2. Net Width [mm]:**

600

**3. Net Depth [mm]:**

600

**4. Net Height [mm]:**

220

**5. Net Weight [kg]:**

45.00

**6. Gross Width [mm]:**

730

**7. Gross depth [mm]:**

630

**8. Gross Height [mm]:**

470

**9. Gross Weight [kg]:**

50.00

**10. Device type:**

Electric unit

**11. Construction type of device:**

Drop-in

**12. Power electric [kW]:**

6.000

**13. Loading:**

400 V / 3N - 50 Hz

**14. Protection of controls:**

IPX5

**15. Device color:**

Stainless steel

**16. Material:**

Stainless steel

**17. Indicators:**

operation and warm-up

**18. Worktop type:**

Molded - comfortable cleaning maintenance

**19. Worktop material:**

Stainless steel

**20. Worktop Thickness [mm]:**

14.00

**21. Standard equipment for device:**

comes with a stainless steel scraper for cleaning pastries

**22. Maximum device temperature [°C]:**

300

**23. Minimum device temperature [°C]:**

50

**24. Service accessibility:**

Trough the frontal panel

**25. Safety thermostat:**

Yes

**26. Griddle dimensions [mm x mm]:**

600 x 600

**27. Griddle thickness [mm]:**

14.00

**28. Independent heating zones:**

Separate control for each heating zone

# Technical data sheet

Technical parameters



**Fry-top griddle plate 56x55 drop-in electric combined 400 V**

<b>Model</b>	<b>SAP Code</b>	00007460
--------------	-----------------	----------

**29. Removable rim:**

Yes

**31. Top type:**

Combinated

**30. Grid size [mm x mm]:**

450 x 595