

Technical data sheet

Product features



Pot and pan washer double skin 50x60 - 400 V

Model	SAP Code	00014556
--------------	-----------------	----------



- Display type: ProScreen - 4 digit display + 2 LED bars
- Number of programs: 9
- Number of skin: 2
- Door clear height [mm]: 400
- Rack size [mm]: 500 x 600
- Water consumption of the washing cycle: 2,4-3,5
- Washing cycle time [s]: 60 - 720
- Detergent and rinse pump system: ProDose - accurate dosing with a peristaltic pump
- Wash pump type: two-way - DuoFlow
- Self-cleaning cycle: Yes
- Drain filter: ArchiMedes - double filtration with overflow discharge ensures only 18% loss of clean water to waste

SAP Code	00014556	Boiler power [kW]	7.000
Net Width [mm]	600	Basin volume [l]	23
Net Depth [mm]	700	Tank power [kW]	2.100
Net Height [mm]	1290	Water consumption of the washing cycle	2,4-3,5
Net Weight [kg]	71.00	Washing cycle time [s]	60 - 720
Power electric [kW]	9.800	Door clear height [mm]	400
Loading	400 V / 3N - 50 Hz	Rack size [mm]	500 x 600
Boiler capacity [l]	6.00		

Technical data sheet

Technical drawing



Pot and pan washer double skin 50x60 - 400 V

Model

SAP Code

00014556

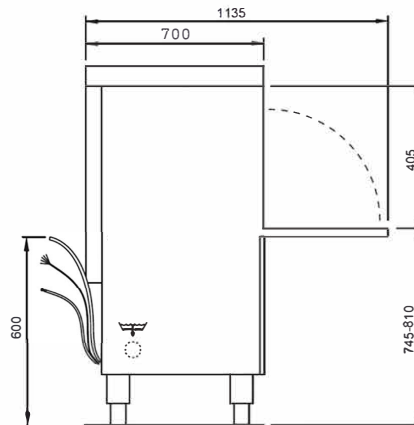
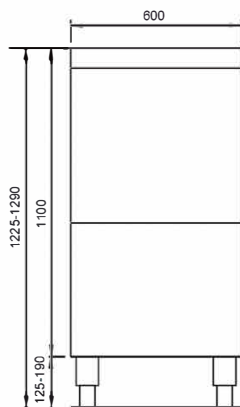

Technical data sheet

Technical parameters



Pot and pan washer double skin 50x60 - 400 V

Model

SAP Code

00014556

1. SAP Code:

00014556

2. Article group:

Dishwashers line N

3. Net Width [mm]:

600

4. Net Depth [mm]:

700

5. Net Height [mm]:

1290

6. Net Weight [kg]:

71.00

7. Gross Width [mm]:

700

8. Gross depth [mm]:

800

9. Gross Height [mm]:

1250

10. Gross Weight [kg]:

77.00

11. Device type:

Electric unit

12. Control type:

Digital

13. Material:

AISI 304

14. Power electric [kW]:

9.800

15. Loading:

400 V / 3N - 50 Hz

16. Number of programs:

9

17. Door clear height [mm]:

400

18. Inlet pressure:

2-4bar

19. Adjustable feet:

Yes

20. Number of skin:

2

21. Self-cleaning cycle:

Yes

22. Boiler capacity [l]:

6.00

23. Boiler power [kW]:

7.000

24. Basin volume [l]:

23

25. Tank power [kW]:

2.100

26. Number of arms for both rinsing and washing:

2

27. Arm connection:

Click-clack - easy removal with one hand

28. Washing arm type:

Rotating trident

Technical data sheet

Technical parameters



Pot and pan washer double skin 50x60 - 400 V

Model

SAP Code

00014556

29. Washing arm material:

Composite

30. Rinsing arm type:

Rotating trident

31. Rinsing arm material:

Composite

32. Deep drawn tank:

Yes

33. Rack support:

Pressed

34. Tank surface strainers:

composite

35. Drain filter:

ArchiMedes - double filtration with overflow discharge ensures only 18% loss of clean water to waste

36. Thermostop:

Yes

37. Boiler thermostat adjust:

Yes

38. Detergent and rinse pump system:

ProDose - accurate dosing with a peristaltic pump

39. Energy Saving system:

EnergySaving - Energy saving system due to lowering the boiler temperature

40. Heating system:

HotWash - System of simultaneous operation of the heating element of the bath and the boiler, reducing the time for starting the next cycle

41. Hot water electric valve:

Yes

42. Rack size [mm]:

500 x 600

43. Display type:

ProScreen - 4 digit display + 2 LED bars

44. USB port:

Yes, for Firmware actualisation

45. Self-diagnostics:

Yes

46. Wash pump type:

two-way - DuoFlow

47. Detergent dispenser:

Yes

48. Rinse aid dispenser:

Yes

49. Water consumption of the washing cycle:

2,4-3,5

50. Washing cycle time [s]:

60 - 720

51. Rinse water temperature [°C]:

80-85

52. Additional information:

The product comes with 1x RM Clean+ 12 kg (00012271) and 1x RM Rinse+ 10 kg (00012273) for free

53. Program ProFessional 2:

Yes

54. Program ProFessional 4:

Yes

Technical data sheet

Technical parameters



Pot and pan washer double skin 50x60 - 400 V

Model

SAP Code

00014556

55. Program ProFessional 6:

Yes

56. Program ProSelf:

Yes

57. Program ProEco:

Yes

58. Program ProLong:

Yes

59. Program ProPlates:

Yes

60. Program ProActive 5:

Yes

61. Program ProActive 7:

Yes